



WAC44

HIGH-EFFICIENCY

SPLIT SYSTEM AIR CONDITIONER

PRODUCT SPECIFICATIONS



UP TO 14 SEER

R-410A

1½ TO 5 TONS

**COOLING CAPACITY
18,000 TO 56,800 BTU/H**

The Whirlpool® brand WAC44 Air Conditioner uses the chlorine-free refrigerant R-410A. This unit features a high-efficiency scroll compressor plus energy efficiencies and operating sound levels that are among the best in the heating and cooling industry. The WAC44 is designed for the consumer who desires superb comfort and quiet operation.

Standard Features

- R-410A chlorine-free refrigerant
- High-efficiency scroll compressor
- High- and low-pressure switches
- High-quality compressor sound blanket
- 850-RPM condenser fan motor
- Liquid refrigerant return protection
- Factory-installed liquid line filter dryer
- Service valves with sweat connections and gauge ports
- Copper tube/enhanced aluminum fin coil
- Contactor with lug connection
- Ground lug connection
- AHRI Certified; ETL Listed

Cabinet Features

- Whirlpool Quiet Partner™ brand sound control top design
- Steel louver coil guard
- Heavy-gauge galvanized-steel cabinet
- Attractive Hannah Slate Gray Dura Shield® powder-paint finish
- Top and side maintenance access
- Single-panel access to controls with space provided for field-installed accessories
- When properly anchored, meets the 2001 Florida Building Code unit integrity requirements for hurricane-type winds (Anchor bracket kits available.)

Contents

Nomenclature.....2
 Product Specifications3
 Expanded Cooling Data4
 AHRI Performance Ratings 18
 Dimensions21
 Wiring Diagram22
 Accessories23



* To receive the Lifetime Compressor Limited Warranty and 10-Year Parts Limited Warranty, online registration must be completed within 60 days of installation. Online registration is not required in California or Québec. Full warranty details available at www.whirlpoolhvac.com.

PRODUCT SPECIFICATIONS

NOMENCLATURE

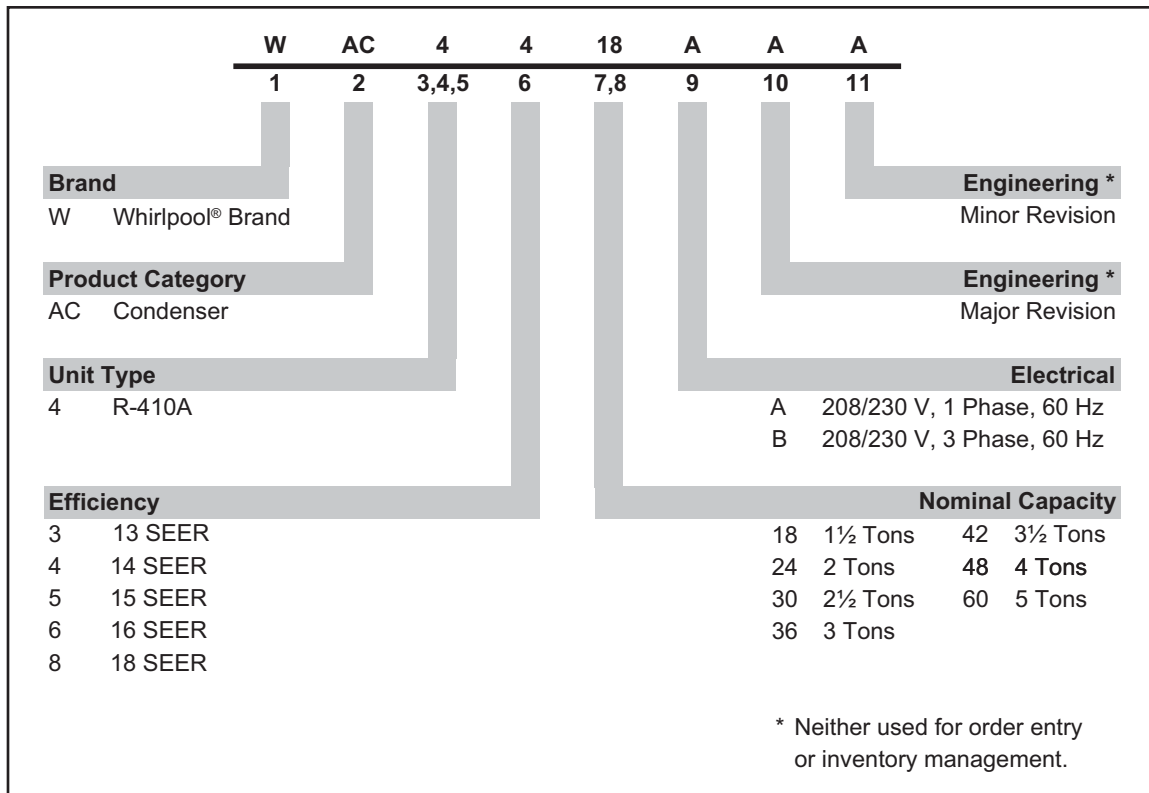

PHYSICAL DATA

Model	Nominal Cooling Capacity (BTU/h)	Voltage-Phase	MOP ¹ (amps)	Dimensions			Service Valve		dBs	Ship Weight (lbs)
				W"	D"	H"	Liquid	Suction		
WAC4418AB*	18,000	208/230-1	20	26	26	27½	¾"	¾"	70	146
WAC4424AB*	24,000	208/230-1	30	26	26	32½	¾"	¾"	71	156
WAC4430AB*	28,800	208/230-1	30	29	29	32½	¾"	¾"	72	172
WAC4436AA*	34,600	208/230-1	30	29	29	34¼	¾"	7/8"	73	199
WAC4442AA*	40,000	208/230-1	40	35½	35½	38¼	¾"	7/8"	73	207
WAC4448AA*	45,000	208/230-1	40	35½	35½	38¼	¾"	7/8"	74	242
WAC4460AA*	56,800	208/230-1	60	35½	35½	38¼	¾"	7/8"	75	280

¹ Maximum Overcurrent Protection Device

Important EnergyStar Notice: Proper sizing and installation of equipment is critical to achieve optimal performance. Split system air conditioners and heat pumps must be matched with appropriate coil components to meet EnergyStar criteria. Ask your contractor for details or visit www.energystar.gov.

SPECIFICATIONS

	WAC 4418AB*	WAC 4424AB*	WAC 4430AB*	WAC 4436AA*	WAC 4442AA*	WAC 4448AA*	WAC 4460AA*
Cooling Capacity							
Nominal Cooling (BTU/h)	18,000	24,000	28,800	34,600	40,000	45,000	56,800
Decibels	71	71	72	73	73	74	75
Compressor							
RLA	9.0	13.4	12.8	14.1	17.9	19.9	26.4
LRA	48.0	58.3	64	77	112.0	109	134
Condenser Fan Motor							
Horsepower (RPM)	1/6	1/12	1/6	1/4	1/4	1/4	1/4
FLA	1.10	0.60	1.10	1.60	1.50	1.50	1.50
Refrigeration System							
Refrigerant Line Size ¹							
Liquid Line Size ("O.D.)	3/8"	3/8"	3/8"	3/8"	3/8"	3/8"	3/8"
Suction Line Size ("O.D.)	3/4"	3/4"	3/4"	7/8"	1 1/8"	1 1/8"	1 1/8"
Refrigerant Connection Size							
Liquid Valve Size ("O.D.)	3/8"	3/8"	3/8"	3/8"	3/8"	3/8"	3/8"
Suction Valve Size ("O.D.)	3/4"	3/4"	3/4"	7/8"	7/8"	7/8"	7/8"
Valve Connection Type	Sweat	Sweat	Sweat	Sweat	Sweat	Sweat	Sweat
Refrigerant Charge	73	91	96	146	174	188	271
Shipped with Orifice Size	0.052	0.055	0.065	0.067	0.074	0.079	0.088
Electrical Data							
Voltage-Hz / Phase			208/230-60-1		208/230-60-1		
Minimum Circuit Ampacity ²	12.4	17.5	17.1	19.2	23.9	26.4	34.5
Max. Overcurrent Protection ³	20	30	30	30	40	45	60
Min / Max Volts	197 / 253	197 / 253	197 / 253	197 / 253	197 / 253	197 / 253	197 / 253
Electrical Conduit Size	1/2" or 3/4"	1/2" or 3/4"	1/2" or 3/4"	1/2" or 3/4"	1/2" or 3/4"	1/2" or 3/4"	1/2" or 3/4"
Ship Weight (lbs)	146	156	172	199	207	242	280

¹ Tested and rated in accordance with ARI Standard 210/240

² Wire size should be determined in accordance with National Electrical Codes; extensive wire runs will require larger wire sizes

³ Must use time-delay fuses or HACR-type circuit breakers of the same size as noted.

Notes

Always check the S&R plate for electrical data on the unit being installed.

Installer will need to supply 7/8" to 1 1/8" adapters for suction line connections.

Unit is charged with refrigerant for 15' of 3/8" liquid line. System charge must be adjusted per Installation Instructions Final Charge Procedure.

Installation of these units requires the specified TXV Kit to be installed on the indoor coil. THE SPECIFIED TXV IS DETERMINED BY THE OUTDOOR UNIT NOT THE INDOOR COIL.

PRODUCT SPECIFICATIONS

EXPANDED COOLING DATA — WAC4418AB* / CA*F3636*6C* / WC*3636P4

IDB	Airflow	Outdoor Ambient Temperature																							
		65°F				75°F				85°F				95°F				105°F				115°F			
		59	63	67	71	59	63	67	71	59	63	67	71	59	63	67	71	59	63	67	71	59	63	67	71
70	MBh	16.7	17.3	18.9	-	16.3	16.9	18.5	-	15.9	16.5	18.1	-	15.5	16.1	17.6	-	14.7	15.3	16.7	-	13.7	14.2	15.5	-
	S/T	0.67	0.56	0.38	-	0.69	0.58	0.40	-	0.71	0.59	0.41	-	0.73	0.61	0.42	-	0.76	0.63	0.44	-	0.76	0.64	0.44	-
	ΔT	19	17	13	-	20	17	13	-	20	17	13	-	20	17	13	-	20	17	13	-	18	16	12	-
	kW	2.00	2.03	2.08	-	2.11	2.14	2.19	-	2.20	2.24	2.29	-	2.29	2.33	2.38	-	2.36	2.40	2.46	-	2.42	2.46	2.53	-
	Amps	4.5	4.6	4.7	-	4.8	4.9	5.1	-	5.2	5.3	5.5	-	5.5	5.7	5.8	-	5.9	6.0	6.2	-	6.2	6.3	6.5	-
	Hi PR	208	224	237	-	234	252	266	-	266	286	302	-	303	326	344	-	341	367	387	-	377	405	428	-
	Lo PR	104	111	121	-	110	117	128	-	115	122	133	-	120	128	140	-	126	134	146	-	130	139	151	-
	MBh	18.1	18.7	20.5	-	17.7	18.3	20.0	-	17.2	17.9	19.6	-	16.8	17.4	19.1	-	16.0	16.6	18.1	-	14.8	15.3	16.8	-
	S/T	0.69	0.58	0.40	-	0.71	0.60	0.41	-	0.73	0.61	0.42	-	0.76	0.63	0.44	-	0.79	0.66	0.45	-	0.79	0.66	0.46	-
	ΔT	19	17	13	-	19	17	13	-	19	17	13	-	19	17	13	-	19	17	13	-	18	16	12	-
	kW	2.03	2.07	2.11	-	2.15	2.18	2.23	-	2.25	2.28	2.34	-	2.33	2.37	2.43	-	2.41	2.45	2.51	-	2.47	2.51	2.58	-
	Amps	4.6	4.7	4.8	-	4.9	5.0	5.2	-	5.3	5.4	5.6	-	5.7	5.8	6.0	-	6.0	6.2	6.4	-	6.4	6.5	6.7	-
Hi PR	215	231	244	-	241	260	274	-	274	295	312	-	312	336	355	-	351	378	399	-	388	418	441	-	
Lo PR	108	114	125	-	114	121	132	-	118	126	137	-	124	132	144	-	130	138	151	-	134	143	156	-	
MBh	18.6	19.3	21.1	-	18.2	18.8	20.7	-	17.8	18.4	20.2	-	17.3	18.0	19.7	-	16.5	17.1	18.7	-	15.2	15.8	17.3	-	
S/T	0.72	0.60	0.42	-	0.75	0.63	0.43	-	0.77	0.64	0.44	-	0.79	0.66	0.46	-	0.82	0.69	0.48	-	0.83	0.69	0.48	-	
ΔT	18	16	12	-	19	16	12	-	19	16	12	-	19	16	12	-	18	16	12	-	17	15	11	-	
kW	2.05	2.08	2.12	-	2.16	2.19	2.25	-	2.26	2.30	2.35	-	2.35	2.39	2.45	-	2.42	2.46	2.53	-	2.49	2.53	2.59	-	
Amps	4.6	4.7	4.9	-	5.0	5.1	5.2	-	5.4	5.5	5.7	-	5.7	5.9	6.0	-	6.1	6.2	6.4	-	6.4	6.6	6.8	-	
Hi PR	217	234	247	-	244	262	277	-	277	298	315	-	315	340	359	-	355	382	403	-	392	422	446	-	
Lo PR	109	116	126	-	115	122	133	-	119	127	139	-	125	133	146	-	131	140	152	-	136	144	158	-	
75	MBh	17.0	17.5	18.9	20.3	16.6	17.1	18.5	19.8	16.2	16.7	18.0	19.4	15.8	16.3	17.6	18.9	15.0	15.4	16.7	17.9	13.9	14.3	15.5	16.6
	S/T	0.76	0.68	0.51	0.33	0.78	0.70	0.53	0.34	0.80	0.72	0.54	0.35	0.83	0.74	0.56	0.36	0.86	0.77	0.58	0.37	0.87	0.78	0.59	0.38
	ΔT	22	21	17	12	23	21	17	12	23	21	17	12	23	21	17	12	23	21	17	12	21	19	16	11
	kW	2.01	2.04	2.09	2.14	2.12	2.15	2.20	2.26	2.22	2.25	2.31	2.37	2.30	2.34	2.40	2.46	2.38	2.42	2.48	2.54	2.44	2.48	2.54	2.61
	Amps	4.5	4.6	4.7	4.9	4.8	4.9	5.1	5.3	5.2	5.4	5.5	5.7	5.6	5.7	5.9	6.1	5.9	6.1	6.2	6.5	6.3	6.4	6.6	6.8
	Hi PR	211	227	239	250	236	254	269	280	269	289	305	319	306	329	348	363	344	371	391	408	380	409	432	451
	Lo PR	105	112	122	130	111	118	129	138	116	123	134	143	122	129	141	150	127	136	148	158	132	140	153	163
	MBh	18.4	18.9	20.5	22.0	18.0	18.5	20.0	21.5	17.5	18.0	19.5	21.0	17.1	17.6	19.1	20.5	16.2	16.7	18.1	19.4	15.0	15.5	16.8	18.0
	S/T	0.78	0.70	0.53	0.34	0.81	0.73	0.55	0.35	0.83	0.75	0.56	0.36	0.86	0.77	0.58	0.37	0.89	0.80	0.60	0.39	0.90	0.81	0.61	0.39
	ΔT	22	20	17	12	22	21	17	12	22	21	17	12	23	21	17	12	22	20	17	12	21	19	16	11
	kW	2.05	2.08	2.12	2.17	2.16	2.19	2.25	2.30	2.26	2.30	2.35	2.41	2.35	2.39	2.45	2.51	2.42	2.46	2.53	2.59	2.49	2.53	2.60	2.66
	Amps	4.6	4.7	4.9	5.0	5.0	5.1	5.2	5.4	5.4	5.5	5.7	5.9	5.7	5.9	6.0	6.3	6.1	6.2	6.4	6.7	6.4	6.6	6.8	7.0
Hi PR	217	234	247	257	244	262	277	289	277	298	315	328	316	340	359	374	355	382	403	421	392	422	446	465	
Lo PR	109	116	126	134	115	122	133	142	119	127	139	148	125	133	146	155	131	140	153	162	136	145	158	168	
MBh	18.9	19.5	21.1	22.6	18.5	19.0	20.6	22.1	18.1	18.6	20.1	21.6	17.6	18.1	19.6	21.1	16.7	17.2	18.6	20.0	15.5	16.0	17.3	18.5	
S/T	0.82	0.74	0.56	0.36	0.85	0.76	0.58	0.37	0.87	0.78	0.59	0.38	0.90	0.81	0.61	0.39	0.94	0.84	0.63	0.41	0.94	0.84	0.64	0.41	
ΔT	21	20	16	11	21	20	16	11	21	20	16	11	22	20	16	11	21	20	16	11	20	18	15	10	
kW	2.06	2.09	2.14	2.19	2.17	2.21	2.26	2.31	2.27	2.31	2.37	2.43	2.36	2.40	2.46	2.53	2.44	2.48	2.54	2.61	2.50	2.55	2.61	2.68	
Amps	4.7	4.8	4.9	5.1	5.0	5.1	5.3	5.5	5.4	5.5	5.7	5.9	5.8	5.9	6.1	6.3	6.1	6.3	6.5	6.7	6.5	6.6	6.8	7.1	
Hi PR	219	236	249	260	246	265	280	292	280	301	318	332	319	343	362	378	359	386	407	425	396	426	450	470	
Lo PR	110	117	127	136	116	123	135	143	120	128	140	149	127	135	147	157	133	141	154	164	137	146	159	170	

IDB: Entering Indoor Dry Bulb Temperature Shaded area reflects ACCA (TVA) conditions
 High and low pressures are measured at the liquid and suction service valves.

kW = Total system power
 Amps = outdoor unit amps (comp.+fan)
 Design Subcooling @ ARI 95°F Conditions, 7° - 9°F @ the Service Valve

EXPANDED COOLING DATA — WAC4418AB* / CA*F3636*6C* / WC*3636P4 (CONT.)

IDB	Airflow	Outdoor Ambient Temperature																							
		65°F				75°F				85°F				95°F				105°F				115°F			
		59	63	67	71	59	63	67	71	59	63	67	71	59	63	67	71	59	63	67	71	59	63	67	71
80	MBh	17.3	17.6	18.9	20.2	16.9	17.2	18.4	19.7	16.5	16.8	18.0	19.2	16.1	16.4	17.5	18.7	15.3	15.6	16.7	17.8	14.1	14.4	15.4	16.5
	S/T	0.83	0.78	0.63	0.47	0.86	0.81	0.66	0.49	0.88	0.83	0.67	0.50	0.91	0.85	0.69	0.52	0.94	0.89	0.72	0.54	0.95	0.89	0.73	0.54
	ΔT	25	24	21	17	25	24	21	17	25	24	21	17	26	25	21	17	25	24	21	17	24	23	20	16
	kW	2.02	2.05	2.10	2.15	2.13	2.17	2.22	2.27	2.23	2.27	2.32	2.38	2.32	2.36	2.41	2.48	2.39	2.43	2.49	2.56	2.45	2.50	2.56	2.63
	Amps	4.5	4.6	4.8	4.9	4.9	5.0	5.1	5.3	5.3	5.4	5.6	5.8	5.6	5.8	5.9	6.2	6.0	6.1	6.3	6.5	6.3	6.5	6.7	6.9
	HiPR	213	229	242	252	239	257	271	283	271	292	308	322	309	333	351	366	348	374	395	412	384	414	437	459
	Lo PR	106	113	124	132	112	120	131	139	117	124	136	145	123	131	143	152	129	137	149	159	133	142	155	165
	MBh	18.7	19.1	20.4	21.8	18.3	18.7	20.0	21.3	17.8	18.2	19.5	20.8	17.4	17.8	19.0	20.3	16.5	16.9	18.1	19.3	15.3	15.6	16.7	17.9
	S/T	0.86	0.81	0.66	0.49	0.89	0.84	0.68	0.51	0.91	0.86	0.70	0.52	0.94	0.88	0.72	0.54	0.98	0.92	0.75	0.56	0.99	0.93	0.75	0.56
	ΔT	25	24	21	16	25	24	21	17	25	24	21	17	25	24	21	17	25	24	21	17	23	22	19	15
	kW	2.06	2.09	2.14	2.19	2.17	2.21	2.26	2.31	2.27	2.31	2.37	2.43	2.36	2.40	2.46	2.53	2.44	2.48	2.54	2.61	2.50	2.55	2.61	2.68
	Amps	4.7	4.8	4.9	5.1	5.0	5.1	5.3	5.5	5.4	5.5	5.7	5.9	5.8	5.9	6.1	6.3	6.1	6.3	6.5	6.7	6.5	6.6	6.9	7.1
HiPR	219	236	249	260	246	265	280	292	280	301	318	332	319	343	362	378	359	386	407	425	396	426	450	470	
Lo PR	110	117	127	136	116	123	135	143	120	128	140	149	127	135	147	157	133	141	154	164	137	146	159	170	
MBh	19.3	19.7	21.0	22.5	18.8	19.2	20.5	22.0	18.4	18.8	20.1	21.4	17.9	18.3	19.6	20.9	17.0	17.4	18.6	19.9	15.8	16.1	17.2	18.4	
S/T	0.90	0.85	0.69	0.51	0.93	0.88	0.71	0.53	0.96	0.90	0.73	0.55	1.00	0.93	0.75	0.56	1.00	0.96	0.78	0.59	1.00	0.97	0.79	0.59	
ΔT	24	23	20	16	24	23	20	16	24	23	20	16	24	23	20	16	24	23	20	16	21	21	19	15	
kW	2.07	2.10	2.15	2.20	2.19	2.22	2.27	2.33	2.29	2.32	2.38	2.44	2.38	2.42	2.48	2.54	2.45	2.50	2.56	2.63	2.52	2.56	2.63	2.70	
Amps	4.7	4.8	4.9	5.1	5.1	5.2	5.3	5.5	5.5	5.6	5.8	6.0	5.8	6.0	6.2	6.4	6.2	6.3	6.5	6.8	6.5	6.7	6.9	7.2	
HiPR	221	238	252	263	249	267	282	295	283	304	321	335	322	346	366	382	362	390	412	429	400	431	455	474	
Lo PR	111	118	129	137	117	125	136	145	122	129	141	151	128	136	148	158	134	143	156	166	139	147	161	171	
MBh	17.6	17.9	18.8	20.0	17.2	17.5	18.3	19.5	16.8	17.1	17.9	19.1	16.3	16.7	17.4	18.6	15.5	15.8	16.6	17.7	14.4	14.7	15.4	16.4	
S/T	0.87	0.84	0.76	0.61	0.90	0.87	0.78	0.64	0.92	0.89	0.80	0.65	0.95	0.92	0.83	0.67	0.99	0.95	0.86	0.70	1.00	0.96	0.87	0.71	
ΔT	27	26	25	22	27	27	25	22	27	27	25	22	27	27	25	22	27	26	25	22	25	25	23	20	
kW	2.03	2.06	2.11	2.16	2.15	2.18	2.23	2.29	2.24	2.28	2.34	2.40	2.33	2.37	2.43	2.49	2.41	2.45	2.51	2.57	2.47	2.51	2.58	2.65	
Amps	4.6	4.7	4.8	5.0	4.9	5.0	5.2	5.4	5.3	5.4	5.6	5.8	5.7	5.8	6.0	6.2	6.0	6.2	6.4	6.6	6.4	6.5	6.7	7.0	
HiPR	215	231	244	255	241	259	274	286	274	295	312	325	312	336	355	370	351	378	399	416	388	418	441	460	
Lo PR	108	114	125	133	114	121	132	140	118	126	137	146	124	132	144	153	130	138	151	161	134	143	156	166	
MBh	19.0	19.4	20.3	21.7	18.6	19.0	19.9	21.2	18.2	18.5	19.4	20.7	17.7	18.1	18.9	20.2	16.8	17.1	18.0	19.2	15.6	15.9	16.6	17.7	
S/T	0.90	0.87	0.79	0.64	0.93	0.90	0.81	0.66	0.96	0.92	0.83	0.68	0.99	0.95	0.86	0.70	1.00	0.99	0.89	0.73	1.00	1.00	0.90	0.73	
ΔT	26	26	24	21	27	26	25	21	27	26	25	21	27	26	25	22	26	26	25	21	24	24	23	20	
kW	2.07	2.10	2.15	2.20	2.19	2.22	2.27	2.33	2.29	2.32	2.38	2.44	2.38	2.42	2.48	2.54	2.45	2.50	2.56	2.63	2.52	2.56	2.63	2.70	
Amps	4.7	4.8	4.9	5.1	5.1	5.2	5.3	5.5	5.5	5.6	5.8	6.0	5.8	6.0	6.2	6.4	6.2	6.3	6.5	6.8	6.5	6.7	6.9	7.2	
HiPR	221	238	252	263	249	267	282	295	283	304	321	335	322	346	366	382	362	390	412	429	400	431	455	474	
Lo PR	111	118	129	137	117	125	136	145	122	129	141	151	128	136	148	158	134	143	156	166	139	147	161	171	
MBh	19.6	20.0	20.9	22.3	19.2	19.5	20.4	21.8	18.7	19.1	20.0	21.3	18.2	18.6	19.5	20.8	17.3	17.7	18.5	19.7	16.1	16.4	17.1	18.3	
S/T	0.95	0.91	0.82	0.67	0.98	0.95	0.85	0.69	1.00	0.97	0.87	0.71	1.00	1.00	0.90	0.73	1.00	1.00	0.94	0.76	1.00	1.00	0.94	0.77	
ΔT	25	25	23	20	26	25	24	21	25	25	24	21	25	25	24	21	24	24	24	20	22	22	22	19	
kW	2.08	2.11	2.16	2.21	2.20	2.23	2.29	2.34	2.30	2.34	2.40	2.46	2.39	2.43	2.49	2.56	2.47	2.51	2.58	2.64	2.54	2.58	2.65	2.72	
Amps	4.7	4.8	5.0	5.2	5.1	5.2	5.4	5.6	5.5	5.6	5.8	6.0	5.9	6.0	6.2	6.4	6.2	6.4	6.6	6.8	6.6	6.8	7.0	7.2	
HiPR	224	241	254	265	251	270	285	298	285	307	324	338	325	350	369	385	366	394	416	434	404	435	459	479	
Lo PR	112	119	130	138	118	126	137	146	123	131	143	152	129	137	150	160	135	144	157	167	140	149	163	173	

IDB: Entering Indoor Dry Bulb Temperature Shaded area reflects ARI conditions
 High and low pressures are measured at the liquid and suction service valves.
 kW = Total system power
 Amps = outdoor unit amps (comp.+fan)
 Design Subcooling @ ARI 95°F Conditions, 7° - 9°F @ the Service Valve

PRODUCT SPECIFICATIONS

EXPANDED COOLING DATA — WAC4424AB* / CA*F3636*6C* / WC*3636P4*

IDB		Outdoor Ambient Temperature																															
		65°F					75°F					85°F					95°F					105°F					115°F						
		59	63	67	71	75	59	63	67	71	75	59	63	67	71	75	59	63	67	71	75	59	63	67	71	75	59	63	67	71	75		
Airflow		Entering Indoor Wet Bulb Temperature																															
70	MBh	23.4	24.2	26.5	-	22.8	23.7	25.9	-	22.3	23.1	25.3	-	21.7	22.5	24.7	-	20.7	21.4	23.5	-	19.1	19.8	21.7	-	20.7	21.4	23.5	-	19.1	19.8	21.7	-
	S/T	0.65	0.54	0.37	-	0.67	0.56	0.39	-	0.69	0.57	0.40	-	0.71	0.59	0.41	-	0.74	0.61	0.43	-	0.74	0.62	0.43	-	0.74	0.61	0.43	-	0.74	0.62	0.43	-
	ΔT	20	17	13	-	20	17	13	-	20	17	13	-	20	18	13	-	20	17	13	-	19	16	12	-	20	17	13	-	19	16	12	-
	kW	1.60	1.63	1.68	-	1.72	1.75	1.81	-	1.82	1.86	1.92	-	1.91	1.95	2.02	-	1.99	2.03	2.10	-	2.06	2.10	2.17	-	1.99	2.03	2.10	-	2.06	2.10	2.17	-
	Amps	5.8	6.0	6.2	-	6.3	6.5	6.7	-	6.9	7.0	7.3	-	7.3	7.5	7.8	-	7.8	8.0	8.3	-	8.3	8.5	8.8	-	7.8	8.0	8.3	-	8.3	8.5	8.8	-
	Hi PR	233	250	264	-	261	281	297	-	297	320	337	-	338	364	384	-	380	409	432	-	420	452	478	-	380	409	432	-	420	452	478	-
	Lo PR	105	112	122	-	111	118	129	-	115	123	134	-	121	129	141	-	127	135	147	-	131	140	152	-	127	135	147	-	131	140	152	-
	MBh	23.6	24.5	26.8	-	23.1	23.9	26.2	-	22.5	23.3	25.6	-	22.0	22.8	24.9	-	20.9	21.6	23.7	-	19.3	20.0	21.9	-	20.9	21.6	23.7	-	19.3	20.0	21.9	-
	S/T	0.65	0.54	0.38	-	0.68	0.56	0.39	-	0.69	0.58	0.40	-	0.72	0.60	0.41	-	0.74	0.62	0.43	-	0.75	0.63	0.43	-	0.74	0.62	0.43	-	0.75	0.63	0.43	-
	ΔT	20	17	13	-	20	17	13	-	20	17	13	-	20	17	13	-	20	17	13	-	18	16	12	-	20	17	13	-	18	16	12	-
70	kW	1.62	1.65	1.70	-	1.74	1.77	1.83	-	1.84	1.88	1.94	-	1.93	1.97	2.04	-	2.01	2.06	2.12	-	2.08	2.13	2.19	-	2.01	2.06	2.12	-	2.08	2.13	2.19	-
	Amps	5.9	6.1	6.2	-	6.4	6.5	6.8	-	6.9	7.1	7.3	-	7.4	7.6	7.9	-	7.9	8.1	8.4	-	8.4	8.6	8.9	-	7.9	8.1	8.4	-	8.4	8.6	8.9	-
	Hi PR	236	254	268	-	265	285	301	-	301	324	342	-	343	369	389	-	385	415	438	-	426	458	484	-	385	415	438	-	426	458	484	-
	Lo PR	106	113	123	-	112	119	130	-	117	124	136	-	123	130	142	-	128	137	149	-	133	141	154	-	128	137	149	-	133	141	154	-
	MBh	24.4	25.3	27.7	-	23.9	24.7	27.1	-	23.3	24.1	26.5	-	22.7	23.6	25.8	-	21.6	22.4	24.5	-	20.0	20.7	22.7	-	21.6	22.4	24.5	-	20.0	20.7	22.7	-
	S/T	0.69	0.58	0.40	-	0.72	0.60	0.42	-	0.74	0.62	0.43	-	0.76	0.64	0.44	-	0.79	0.66	0.46	-	0.80	0.66	0.46	-	0.79	0.66	0.46	-	0.80	0.66	0.46	-
	ΔT	17	15	11	-	18	15	12	-	18	15	12	-	18	15	12	-	17	15	11	-	16	14	11	-	17	15	11	-	16	14	11	-
	kW	1.64	1.67	1.72	-	1.76	1.80	1.85	-	1.87	1.91	1.97	-	1.96	2.01	2.07	-	2.04	2.09	2.16	-	2.11	2.16	2.23	-	2.04	2.09	2.16	-	2.11	2.16	2.23	-
	Amps	6.0	6.2	6.4	-	6.5	6.7	6.9	-	7.1	7.2	7.5	-	7.6	7.7	8.0	-	8.0	8.2	8.5	-	8.5	8.7	9.0	-	8.0	8.2	8.5	-	8.5	8.7	9.0	-
	Hi PR	240	259	273	-	270	290	307	-	307	330	349	-	349	376	397	-	393	423	447	-	434	467	494	-	393	423	447	-	434	467	494	-
Lo PR	108	115	126	-	115	122	133	-	119	127	138	-	125	133	145	-	131	139	152	-	136	144	157	-	131	139	152	-	136	144	157	-	
75	MBh	23.8	24.5	26.5	28.4	23.2	23.9	25.9	27.8	22.7	23.3	25.3	27.1	22.1	22.8	24.6	26.4	21.0	21.6	23.4	25.1	19.5	20.0	21.7	23.3	21.0	21.6	23.4	25.1	19.5	20.0	21.7	23.3
	S/T	0.73	0.66	0.50	0.32	0.76	0.68	0.51	0.33	0.78	0.70	0.53	0.34	0.81	0.72	0.55	0.35	0.84	0.75	0.57	0.36	0.84	0.75	0.57	0.37	0.84	0.75	0.57	0.36	0.84	0.75	0.57	0.37
	ΔT	23	21	17	12	23	21	17	12	23	21	18	12	23	22	18	12	23	21	17	12	22	20	16	11	23	21	17	12	22	20	16	11
	kW	1.61	1.64	1.69	1.75	1.73	1.77	1.82	1.88	1.84	1.87	1.93	2.00	1.93	1.97	2.03	2.10	2.01	2.05	2.12	2.19	2.08	2.12	2.19	2.26	2.01	2.05	2.12	2.19	2.08	2.12	2.19	2.26
	Amps	5.9	6.0	6.2	6.5	6.4	6.5	6.7	7.0	6.9	7.1	7.3	7.6	7.4	7.6	7.8	8.1	7.9	8.1	8.3	8.7	8.3	8.5	8.8	9.2	7.9	8.1	8.3	8.7	8.3	8.5	8.8	9.2
	Hi PR	235	253	267	279	264	284	300	313	300	323	341	356	342	368	388	405	384	414	437	456	425	457	483	503	384	414	437	456	425	457	483	503
	Lo PR	106	113	123	131	112	119	130	139	116	124	135	144	122	130	142	151	128	136	149	158	133	141	154	164	128	136	149	158	133	141	154	164
	MBh	24.0	24.7	26.8	28.7	23.4	24.1	26.1	28.0	22.9	23.6	25.5	27.4	22.3	23.0	24.9	26.7	21.2	21.8	23.6	25.4	19.6	20.2	21.9	23.5	21.2	21.8	23.6	25.4	19.6	20.2	21.9	23.5
	S/T	0.74	0.66	0.50	0.32	0.77	0.69	0.52	0.33	0.79	0.70	0.53	0.34	0.81	0.73	0.55	0.35	0.84	0.76	0.57	0.37	0.85	0.76	0.58	0.37	0.84	0.76	0.57	0.37	0.85	0.76	0.58	0.37
	ΔT	23	21	17	12	23	21	17	12	23	21	17	12	23	21	17	12	23	21	17	12	21	20	16	11	23	21	17	12	21	20	16	11
kW	1.63	1.66	1.71	1.77	1.75	1.79	1.84	1.90	1.86	1.89	1.95	2.02	1.95	1.99	2.05	2.12	2.03	2.07	2.14	2.21	2.10	2.14	2.21	2.29	2.03	2.07	2.14	2.21	2.10	2.14	2.21	2.29	
Amps	6.0	6.1	6.3	6.5	6.4	6.6	6.8	7.1	7.0	7.2	7.4	7.7	7.5	7.7	7.9	8.2	8.0	8.2	8.4	8.8	8.4	8.7	8.9	9.3	8.0	8.2	8.4	8.8	8.4	8.7	8.9	9.3	
Hi PR	238	256	271	282	267	288	304	317	304	327	345	360	346	372	393	410	389	419	442	462	430	463	489	510	389	419	442	462	430	463	489	510	
Lo PR	107	114	125	133	113	121	132	140	118	125	137	146	124	132	144	153	130	138	151	161	134	143	156	166	130	138	151	161	134	143	156	166	
MBh	24.8	25.6	27.7	29.7	24.3	25.0	27.0	29.0	23.7	24.4	26.4	28.3	23.1	23.8	25.8	27.6	22.0	22.6	24.5	26.3	20.3	20.9	22.7	24.3	22.0	22.6	24.5	26.3	20.3	20.9	22.7	24.3	
S/T	0.79	0.70	0.53	0.34	0.82	0.73	0.55	0.36	0.84	0.75	0.57	0.36	0.86	0.77	0.59	0.38	0.90	0.80	0.61	0.39	0.90	0.81	0.61	0.39	0.90	0.80	0.61	0.39	0.90	0.81	0.61	0.39	
ΔT	20	18	15	10	20	19	15	11	20	19	15	11	20	19	15	11	20	19	15	10	19	17	14	10	20	19	15	10	19	17	14	10	
900	kW	1.65	1.69	1.74	1.79	1.78	1.81	1.87	1.93	1.88	1.92	1.99	2.05	1.98	2.02	2.09	2.16	2.06	2.11	2.17	2.25	2.13	2.18	2.25	2.32	2.06	2.11	2.17	2.25	2.13	2.18	2.25	2.32
	Amps	6.1	6.2	6.4	6.7	6.6	6.7	6.9	7.2	7.1	7.3	7.5	7.8	7.6	7.8	8.1	8.4	8.1	8.3	8.6	8.9	8.6	8.8	9.1	9.5	8.1	8.3	8.6	8.9	8.6	8.8	9.1	9.5
	Hi PR	243	261	276	288	273	293	310	323	310	334	352	367	353	380	401	418	397	427	451	471	439	472	499	520	401	418	439	471	439	472	499	520
	Lo PR	110	117	127	135	116	123	134	143	120	128	140	149	126	134	147	156	132	141	154	164	137	146	159	169	132	141	154	164	137	146	159	169
	MBh	24.9	25.8	28.0	30.0	24.5	25.2	27.4	29.4	24.0	24.7	26.9	28.9	23.6	24.3	26.5	28.5	23.1	23.8	25.9	27.9	21.7	22.4	24.5	26.5	23.1	23.8	25.9	27.9	21.7	22.4	24.5	26.5
	S/T	0.79	0.70	0.53	0.34	0.82	0.73	0.55	0.36	0.84	0.75	0.57	0.36	0.86	0.77	0.59	0.38	0.90	0.80	0.61	0.39	0.90	0.81	0.61</									

EXPANDED COOLING DATA — WAC4424AB* / CA*F3636*6C* / WC*3636P4* (CONT.)

IDB	Airflow	Outdoor Ambient Temperature																									
		65°F				75°F				85°F				95°F				105°F				115°F					
		59	63	67	71	59	63	67	71	59	63	67	71	59	63	67	71	59	63	67	71	59	63	67	71		
80	700	MBh	24.2	24.7	26.4	28.2	23.6	24.1	25.8	27.6	23.1	23.6	25.2	26.9	22.5	23.0	24.6	26.3	21.4	21.8	23.3	24.9	19.8	20.2	21.6	23.1	
		S/T	0.81	0.76	0.61	0.46	0.83	0.78	0.64	0.48	0.86	0.80	0.65	0.49	0.88	0.83	0.67	0.50	0.92	0.86	0.70	0.52	0.92	0.87	0.71	0.53	
		ΔT	26	25	21	17	26	25	22	17	26	25	22	17	26	25	22	17	26	25	21	17	24	23	20	16	
		kW	1.62	1.66	1.71	1.76	1.74	1.78	1.84	1.89	1.85	1.89	1.95	2.01	1.94	1.99	2.05	2.12	2.02	2.07	2.13	2.20	2.09	2.14	2.21	2.28	
		Amps	5.9	6.1	6.3	6.5	6.4	6.6	6.8	7.1	7.0	7.2	7.4	7.7	7.5	7.6	7.9	8.2	7.9	8.1	8.4	8.7	8.4	8.6	8.9	9.3	
	Hi PR	237	255	270	281	266	287	303	316	303	326	344	359	345	371	392	409	388	418	441	460	429	462	487	508		
	Lo PR	107	114	124	132	113	120	131	140	118	125	137	145	123	131	143	153	129	138	150	160	134	142	155	166		
	725	MBh	24.4	25.0	26.7	28.5	23.9	24.4	26.1	27.8	23.3	23.8	25.4	27.2	22.7	23.2	24.8	26.5	21.6	22.1	23.6	25.2	20.0	20.4	21.8	23.3	
		S/T	0.81	0.76	0.62	0.46	0.84	0.79	0.64	0.48	0.86	0.81	0.66	0.49	0.89	0.84	0.68	0.51	0.93	0.87	0.71	0.53	0.93	0.88	0.71	0.53	
		ΔT	25	24	21	17	26	24	21	17	26	24	21	17	26	25	21	17	25	24	21	17	24	23	20	16	
kW		1.64	1.67	1.73	1.78	1.76	1.80	1.86	1.91	1.87	1.91	1.97	2.03	1.96	2.01	2.07	2.14	2.05	2.09	2.16	2.23	2.11	2.16	2.23	2.31		
Amps		6.0	6.2	6.4	6.6	6.5	6.7	6.9	7.1	7.1	7.2	7.5	7.8	7.6	7.7	8.0	8.3	8.0	8.2	8.5	8.8	8.5	8.7	9.0	9.4		
Hi PR	241	259	273	285	270	290	307	320	307	330	349	364	350	376	397	414	393	423	447	466	435	468	494	515			
Lo PR	108	115	126	134	115	122	133	142	119	127	138	147	125	133	145	155	131	139	152	162	136	144	158	168			
900	700	MBh	25.3	25.8	27.6	29.5	24.7	25.2	27.0	28.8	24.1	24.6	26.3	28.1	23.5	24.0	25.7	27.5	22.3	22.8	24.4	26.1	20.7	21.2	22.6	24.2	
		S/T	0.86	0.81	0.66	0.49	0.90	0.84	0.68	0.51	0.92	0.86	0.70	0.52	0.95	0.89	0.72	0.54	1.00	0.92	0.75	0.56	1.00	0.93	0.76	0.57	
		ΔT	22	21	19	15	23	22	19	15	23	22	19	15	23	22	19	15	23	22	19	15	21	20	17	14	
		kW	1.67	1.70	1.75	1.81	1.79	1.83	1.88	1.94	1.90	1.94	2.00	2.07	2.00	2.04	2.10	2.17	2.08	2.12	2.19	2.26	2.15	2.20	2.27	2.34	
		Amps	6.1	6.3	6.5	6.7	6.6	6.8	7.0	7.3	7.2	7.4	7.6	7.9	7.7	7.9	8.1	8.5	8.2	8.4	8.7	9.0	8.7	8.9	9.2	9.5	
	Hi PR	245	264	279	291	275	296	313	326	313	337	356	371	357	384	405	423	401	432	456	476	443	477	504	525		
	Lo PR	111	118	128	137	117	124	136	145	121	129	141	150	128	136	148	158	134	142	155	165	138	147	161	171		
	85	700	MBh	24.6	25.1	26.3	28.0	24.0	24.5	25.7	27.4	23.5	23.9	25.1	26.7	22.9	23.3	24.4	26.1	21.7	22.2	23.2	24.8	20.1	20.5	21.5	22.9
			S/T	0.84	0.81	0.73	0.60	0.87	0.84	0.76	0.62	0.90	0.87	0.78	0.63	0.93	0.89	0.81	0.65	0.96	0.93	0.84	0.68	0.97	0.93	0.84	0.68
			ΔT	27	27	25	22	28	27	26	22	28	27	26	22	28	27	26	22	27	27	26	22	26	25	24	21
kW			1.64	1.67	1.72	1.77	1.76	1.79	1.85	1.91	1.87	1.90	1.96	2.03	1.96	2.00	2.07	2.13	2.04	2.08	2.15	2.22	2.11	2.16	2.23	2.30	
Amps			6.0	6.1	6.3	6.6	6.5	6.6	6.9	7.1	7.0	7.2	7.5	7.7	7.5	7.7	8.0	8.3	8.0	8.2	8.5	8.8	8.5	8.7	9.0	9.3	
Hi PR		240	258	272	284	269	290	306	319	306	329	348	363	349	375	396	413	392	422	446	465	433	466	492	513		
Lo PR		108	115	126	134	114	122	133	141	119	126	138	147	125	133	145	154	131	139	152	162	135	144	157	167		
725		MBh	24.9	25.3	26.5	28.3	24.3	24.7	25.9	27.7	23.7	24.2	25.3	27.0	23.1	23.6	24.7	26.3	22.0	22.4	23.5	25.0	20.3	20.7	21.7	23.2	
		S/T	0.85	0.82	0.74	0.60	0.88	0.85	0.77	0.62	0.91	0.87	0.79	0.64	0.94	0.90	0.81	0.66	0.97	0.94	0.85	0.69	0.98	0.94	0.85	0.69	
		ΔT	27	26	25	22	27	27	25	22	27	27	25	22	27	27	25	22	27	27	25	22	25	25	23	20	
	kW	1.65	1.69	1.74	1.79	1.78	1.81	1.87	1.93	1.88	1.92	1.99	2.05	1.98	2.02	2.09	2.16	2.06	2.11	2.17	2.25	2.13	2.18	2.25	2.32		
	Amps	6.1	6.2	6.4	6.7	6.6	6.7	6.9	7.2	7.1	7.3	7.6	7.8	7.6	7.8	8.1	8.4	8.1	8.3	8.6	8.9	8.6	8.8	9.1	9.5		
Hi PR	243	261	276	288	273	293	310	323	310	334	352	367	353	380	401	419	397	428	451	471	439	472	499	520			
Lo PR	110	117	127	136	116	123	134	143	120	128	140	149	126	134	147	156	132	141	154	164	137	146	159	169			
900	700	MBh	25.7	26.2	27.5	29.3	25.1	25.6	26.8	28.6	24.5	25.0	26.2	27.9	23.9	24.4	25.5	27.3	22.7	23.2	24.3	25.9	21.1	21.5	22.5	24.0	
		S/T	0.91	0.87	0.79	0.64	0.94	0.91	0.82	0.66	0.96	0.93	0.84	0.68	0.99	0.96	0.87	0.70	1.00	1.00	0.90	0.73	1.00	1.00	0.91	0.73	
		ΔT	24	23	22	19	24	24	22	19	24	24	22	19	24	24	23	20	23	24	22	19	22	22	21	18	
		kW	1.68	1.71	1.77	1.82	1.80	1.84	1.90	1.96	1.91	1.96	2.02	2.08	2.01	2.06	2.12	2.19	2.02	2.06	2.12	2.19	2.17	2.21	2.29	2.36	
		Amps	6.2	6.3	6.5	6.8	6.7	6.8	7.1	7.3	7.3	7.4	7.7	8.0	7.8	8.0	8.2	8.5	8.3	8.5	8.8	9.1	8.8	9.0	9.3	9.6	
	Hi PR	248	267	282	294	278	299	316	330	316	340	359	375	360	388	409	427	405	436	460	480	448	482	509	531		
	Lo PR	112	119	130	138	118	126	137	146	123	131	143	152	129	137	150	159	135	144	157	167	140	149	162	173		

IDB: Entering Indoor Dry Bulb Temperature. Shaded area reflects ARI conditions. High and low pressures are measured at the liquid and suction service valves.

kW = Total system power

Amps = outdoor unit amps (comp. + fan)

PRODUCT SPECIFICATIONS

EXPANDED COOLING DATA — WAC4430AB* / CA*F3642*6C* / WC*3642P4*

IDB	Airflow	Outdoor Ambient Temperature												115°F													
		65°F				75°F				85°F					95°F				105°F								
		59	63	67	71	59	63	67	71	59	63	67	71		59	63	67	71	59	63	67	71					
70	875	MBh	25.3	26.2	28.7	-	24.7	25.6	28.1	-	24.1	25.0	27.4	-	23.5	24.4	26.7	-	22.3	23.2	25.4	-	20.7	21.5	23.5	-	
		S/T	0.68	0.57	0.40	-	0.71	0.59	0.41	-	0.73	0.61	0.42	-	0.75	0.63	0.43	-	0.78	0.65	0.45	-	0.79	0.66	0.45	-	
		ΔT	18	16	12	-	18	16	12	-	18	16	12	-	19	16	12	-	18	16	12	-	17	15	11	-	
		KW	1.92	1.96	2.01	-	2.05	2.09	2.15	-	2.17	2.21	2.27	-	2.27	2.31	2.38	-	2.35	2.40	2.47	-	2.43	2.47	2.55	-	
		Amps	6.8	6.9	7.1	-	7.3	7.5	7.7	-	7.9	8.1	8.3	-	8.4	8.6	8.9	-	8.9	9.1	9.4	-	9.4	9.7	10.0	-	
		Hi-PR	217	234	247	-	244	262	277	-	277	298	315	-	316	340	359	-	355	382	404	-	393	423	446	-	
	Lo-PR	105	112	122	-	111	118	129	-	115	123	134	-	121	129	141	-	127	135	148	-	131	140	153	-		
	MBh	27.4	28.4	31.1	-	26.8	27.7	30.4	-	26.1	27.1	29.7	-	25.5	26.4	28.9	-	24.2	25.1	27.5	-	22.4	23.2	25.5	-		
	S/T	0.71	0.59	0.41	-	0.74	0.61	0.43	-	0.75	0.63	0.44	-	0.78	0.65	0.45	-	0.81	0.67	0.47	-	0.81	0.68	0.47	-		
	ΔT	18	15	12	-	18	16	12	-	18	16	12	-	18	16	12	-	18	16	12	-	17	15	11	-		
	KW	1.97	2.00	2.06	-	2.10	2.14	2.20	-	2.22	2.26	2.32	-	2.32	2.36	2.43	-	2.41	2.45	2.53	-	2.48	2.53	2.61	-		
	Amps	7.0	7.1	7.3	-	7.5	7.7	7.9	-	8.1	8.3	8.6	-	8.6	8.8	9.1	-	9.2	9.4	9.7	-	9.7	9.9	10.3	-		
Hi-PR	224	241	255	-	251	271	286	-	286	308	325	-	326	350	370	-	366	394	416	-	405	436	460	-			
Lo-PR	108	115	126	-	115	122	133	-	119	127	138	-	125	133	145	-	131	139	152	-	136	144	157	-			
1125	875	MBh	28.2	29.3	32.0	-	27.6	28.6	31.3	-	26.9	27.9	30.6	-	26.3	27.2	29.8	-	24.9	25.8	28.3	-	23.1	23.9	26.2	-	
		S/T	0.74	0.62	0.43	-	0.77	0.64	0.45	-	0.79	0.66	0.46	-	0.82	0.68	0.47	-	0.85	0.71	0.49	-	0.85	0.71	0.49	-	
		ΔT	17	15	11	-	17	15	11	-	17	15	11	-	18	15	12	-	17	15	11	-	16	14	11	-	
		KW	1.98	2.02	2.07	-	2.11	2.15	2.22	-	2.23	2.28	2.34	-	2.34	2.38	2.45	-	2.42	2.47	2.55	-	2.50	2.55	2.63	-	
		Amps	7.0	7.2	7.4	-	7.6	7.7	8.0	-	8.2	8.4	8.6	-	8.7	8.9	9.2	-	9.3	9.5	9.8	-	9.8	10.0	10.4	-	
		Hi-PR	226	244	257	-	254	273	289	-	289	311	328	-	329	354	374	-	370	398	420	-	409	440	465	-	
	Lo-PR	110	116	127	-	116	123	134	-	120	128	140	-	126	134	147	-	132	141	154	-	137	146	159	-		
	75	875	MBh	25.7	26.5	28.7	30.8	25.1	25.9	28.0	30.0	24.5	25.2	27.3	29.3	23.9	24.6	26.7	28.6	22.7	23.4	25.3	27.2	21.1	21.7	23.5	25.2
			S/T	0.78	0.70	0.53	0.34	0.81	0.72	0.55	0.35	0.83	0.74	0.56	0.36	0.85	0.76	0.58	0.37	0.89	0.79	0.60	0.39	0.89	0.80	0.60	0.39
			ΔT	21	19	16	11	21	20	16	11	21	20	16	11	21	20	16	11	21	19	16	11	20	18	15	10
			KW	1.94	1.97	2.03	2.09	2.07	2.11	2.17	2.23	2.18	2.23	2.29	2.36	2.28	2.33	2.40	2.47	2.37	2.42	2.49	2.57	2.44	2.49	2.57	2.65
			Amps	6.8	7.0	7.2	7.5	7.4	7.5	7.8	8.0	8.0	8.2	8.4	8.7	8.5	8.7	9.0	9.3	9.0	9.2	9.5	9.9	9.5	9.8	10.1	10.5
Hi-PR			220	236	249	260	246	265	280	292	280	301	318	332	319	343	363	378	359	386	408	425	397	427	451	470	
75	1000	MBh	27.9	28.7	31.1	33.3	27.2	28.0	30.3	32.6	26.6	27.4	29.6	31.8	25.9	26.7	28.9	31.0	24.6	25.4	27.4	29.5	22.8	23.5	25.4	27.3	
		S/T	0.81	0.72	0.55	0.35	0.84	0.75	0.57	0.36	0.86	0.77	0.58	0.37	0.89	0.79	0.60	0.39	0.92	0.82	0.62	0.40	0.93	0.83	0.63	0.40	
		ΔT	21	19	16	11	21	19	16	11	21	19	16	11	21	19	16	11	21	19	16	11	19	18	15	10	
		KW	1.98	2.02	2.07	2.13	2.11	2.15	2.22	2.28	2.23	2.28	2.34	2.41	2.34	2.38	2.45	2.53	2.43	2.47	2.55	2.63	2.50	2.55	2.63	2.71	
		Amps	7.0	7.2	7.4	7.7	7.6	7.7	8.0	8.3	8.2	8.4	8.6	9.0	8.7	8.9	9.2	9.6	9.3	9.5	9.8	10.2	9.8	10.0	10.4	10.7	
		Hi-PR	226	244	257	268	254	273	289	301	289	311	328	342	329	354	374	390	370	398	421	439	409	440	465	485	
1125	1000	MBh	28.7	29.5	32.0	34.3	28.0	28.9	31.2	33.5	27.4	28.2	30.5	32.7	26.7	27.5	29.8	31.9	25.4	26.1	28.3	30.3	23.5	24.2	26.2	28.1	
		S/T	0.85	0.76	0.57	0.37	0.88	0.78	0.59	0.38	0.90	0.80	0.61	0.39	0.93	0.83	0.63	0.40	0.96	0.86	0.65	0.42	0.97	0.87	0.66	0.42	
		ΔT	20	18	15	10	20	18	15	10	20	19	15	10	20	19	15	10	20	18	15	10	19	17	14	10	
		KW	1.99	2.03	2.09	2.15	2.13	2.17	2.23	2.30	2.25	2.29	2.36	2.43	2.35	2.40	2.47	2.55	2.44	2.49	2.57	2.65	2.52	2.57	2.65	2.73	
		Amps	7.1	7.2	7.5	7.7	7.6	7.8	8.0	8.3	8.3	8.4	8.7	9.0	8.8	9.0	9.3	9.6	9.3	9.6	9.9	10.2	9.9	10.1	10.5	10.8	
		Hi-PR	229	246	260	271	257	276	291	304	292	314	331	346	332	358	378	394	374	402	425	443	413	444	469	489	
Lo-PR	111	118	128	137	117	124	136	145	121	129	141	150	128	136	148	158	134	142	155	165	138	147	161	171			

IDB: Entering Indoor Dry Bulb Temperature Shaded area reflects ACCA (TVA) conditions High and low pressures are measured at the liquid and suction service valves. kW = Total system power Amps = outdoor unit amps (comp.+fan)

EXPANDED COOLING DATA — WAC4430AB* / CA*F3642*6C* / WC*3642P4* (CONT.)

IDB	Airflow	Outdoor Ambient Temperature												115°F												
		65°F			75°F			85°F			95°F				105°F											
		59	63	67	71	59	63	67	71	59	63	67	71		59	63	67	71								
80	875	MBh	26.2	26.7	28.6	30.5	25.6	26.1	27.9	29.8	25.0	25.5	27.2	29.1	24.3	24.9	26.6	28.4	23.1	23.6	25.3	27.0	21.4	21.9	23.4	25.0
		S/T	0.85	0.80	0.65	0.49	0.88	0.83	0.68	0.50	0.91	0.85	0.69	0.52	0.94	0.88	0.71	0.53	0.97	0.91	0.74	0.55	0.98	0.92	0.75	0.56
		ΔT	23	22	20	16	24	23	20	16	24	23	20	16	24	23	20	16	24	23	20	16	22	21	18	15
		kW	1.95	1.99	2.04	2.10	2.08	2.12	2.18	2.25	2.20	2.24	2.31	2.38	2.30	2.35	2.42	2.49	2.39	2.44	2.51	2.58	2.46	2.51	2.59	2.67
		Amps	6.9	7.1	7.3	7.5	7.4	7.6	7.8	8.1	8.0	8.2	8.5	8.8	8.6	8.8	9.1	9.4	9.1	9.3	9.6	10.0	9.6	9.8	10.2	10.5
		Hi PR	222	239	252	263	249	268	283	295	283	305	322	335	322	347	366	382	363	390	412	430	401	431	455	475
	1000	Lo PR	107	114	125	133	113	121	132	140	118	125	137	146	124	132	144	153	130	138	151	160	134	143	156	166
		MBh	28.4	29.0	31.0	33.1	27.7	28.3	30.2	32.3	27.0	27.6	29.5	31.6	26.4	27.0	28.8	30.8	25.1	25.6	27.4	29.2	23.2	23.7	25.3	27.1
		S/T	0.88	0.83	0.68	0.50	0.92	0.86	0.70	0.52	0.94	0.88	0.72	0.54	0.97	0.91	0.74	0.55	1.00	0.94	0.77	0.57	1.00	0.95	0.78	0.58
		ΔT	23	22	19	15	23	22	19	16	23	22	19	16	24	23	20	16	23	22	19	15	21	21	18	14
		kW	1.99	2.03	2.09	2.15	2.13	2.17	2.23	2.30	2.25	2.29	2.36	2.43	2.35	2.40	2.47	2.55	2.44	2.49	2.57	2.65	2.52	2.57	2.65	2.73
		Amps	7.1	7.2	7.5	7.7	7.6	7.8	8.0	8.3	8.3	8.4	8.7	9.0	8.8	9.0	9.3	9.6	9.3	9.6	9.9	10.2	9.9	10.1	10.5	10.8
1125	Hi PR	229	246	260	271	257	276	292	304	292	314	332	346	332	358	378	394	374	402	425	443	413	444	469	490	
	Lo PR	111	118	128	137	117	124	136	145	121	129	141	150	128	136	148	158	134	142	155	165	138	147	161	171	
	MBh	29.2	29.8	31.9	34.1	28.5	29.2	31.1	33.3	27.9	28.5	30.4	32.5	27.2	27.8	29.7	31.7	25.8	26.4	28.2	30.1	23.9	24.4	26.1	27.9	
	S/T	0.93	0.87	0.71	0.53	0.96	0.90	0.73	0.55	1.00	0.92	0.75	0.56	1.00	0.95	0.78	0.58	1.00	1.00	0.81	0.60	1.00	1.00	0.81	0.61	
	ΔT	22	21	18	15	22	21	19	15	23	22	19	15	22	22	19	15	21	22	19	15	20	20	17	14	
	kW	2.01	2.05	2.10	2.16	2.14	2.19	2.25	2.31	2.26	2.31	2.38	2.45	2.37	2.42	2.49	2.57	2.46	2.51	2.59	2.67	2.54	2.59	2.67	2.75	
85	875	Amps	7.1	7.3	7.5	7.8	7.7	7.9	8.1	8.4	8.3	8.5	8.8	9.1	8.9	9.1	9.4	9.7	9.4	9.7	10.0	10.3	10.0	10.2	10.5	10.9
		Hi PR	231	248	262	274	259	279	294	307	295	317	335	349	336	361	381	398	378	406	429	447	417	449	474	494
		Lo PR	112	119	130	138	118	126	137	146	123	131	142	152	129	137	150	159	135	144	157	167	140	149	162	173
		MBh	26.6	27.1	28.4	30.3	26.0	26.5	27.8	29.6	25.4	25.9	27.1	28.9	24.8	25.3	26.4	28.2	23.5	24.0	25.1	26.8	21.8	22.2	23.3	24.8
		S/T	0.89	0.86	0.78	0.63	0.93	0.89	0.81	0.65	0.95	0.92	0.83	0.67	0.98	0.95	0.85	0.69	1.00	0.98	0.89	0.72	1.00	0.99	0.89	0.73
		ΔT	25	25	23	20	25	25	24	20	25	25	24	20	26	25	24	21	25	25	23	20	23	23	22	19
	1000	kW	1.97	2.00	2.06	2.12	2.10	2.14	2.20	2.26	2.21	2.26	2.32	2.39	2.32	2.36	2.43	2.51	2.41	2.45	2.53	2.60	2.48	2.53	2.61	2.69
		Amps	7.0	7.1	7.3	7.6	7.5	7.7	7.9	8.2	8.1	8.3	8.6	8.9	8.6	8.8	9.1	9.5	9.2	9.4	9.7	10.1	9.7	9.9	10.3	10.6
		Hi PR	224	241	255	265	251	270	286	298	286	308	325	339	326	350	370	386	366	394	416	434	405	435	460	480
		Lo PR	108	115	126	134	115	122	133	142	119	127	138	147	125	133	145	155	131	139	152	162	136	144	157	168
		MBh	28.9	29.4	30.8	32.9	28.2	28.7	30.1	32.1	27.5	28.0	29.4	31.3	26.8	27.4	28.7	30.6	25.5	26.0	27.2	29.0	23.6	24.1	25.2	26.9
		S/T	0.93	0.90	0.81	0.66	0.96	0.93	0.84	0.68	0.99	0.95	0.86	0.70	1.00	0.98	0.89	0.72	1.00	1.00	0.92	0.75	1.00	1.00	0.93	0.75
1125	ΔT	25	24	23	20	25	25	23	20	25	25	23	20	25	25	23	20	23	24	23	20	22	22	22	19	
	kW	2.01	2.05	2.10	2.16	2.14	2.19	2.25	2.31	2.26	2.31	2.38	2.45	2.37	2.42	2.49	2.57	2.46	2.51	2.59	2.67	2.54	2.59	2.67	2.75	
	Amps	7.1	7.3	7.5	7.8	7.7	7.9	8.1	8.4	8.3	8.5	8.8	9.1	8.9	9.1	9.4	9.7	9.4	9.7	10.0	10.3	10.0	10.2	10.5	10.9	
	Hi PR	231	248	262	274	259	279	294	307	295	317	335	349	336	361	381	398	378	406	429	447	417	449	474	494	
	Lo PR	113	120	131	140	119	127	138	147	124	132	144	153	130	138	151	161	136	145	158	169	141	150	164	175	
	MBh	26.6	27.1	28.4	30.3	26.0	26.5	27.8	29.6	25.4	25.9	27.1	28.9	24.8	25.3	26.4	28.2	23.5	24.0	25.1	26.8	21.8	22.2	23.3	24.8	

IDB: Entering Indoor Dry Bulb Temperature Shaded area reflects ARI conditions
 High and low pressures are measured at the liquid and suction service valves.
 kW = Total system power
 Amps = outdoor unit amps (comp. +fan)

PRODUCT SPECIFICATIONS

EXPANDED COOLING DATA — WAC4436AA* / CA*F3642C6A* / WC*3642P4* / .067 ORIFICE

IDB*	Airflow	Outdoor Ambient Temperature																									
		65°F				75°F				85°F				95°F				105°F				115°F					
		59	63	67	71	59	63	67	71	59	63	67	71	59	63	67	71	59	63	67	71	59	63	67	71		
70	1300	MBh	33.9	35.1	38.5	-	33.1	34.3	37.6	-	32.3	33.5	36.7	-	31.5	32.7	35.8	-	30.0	31.1	34.0	-	27.8	28.8	31.5	-	
		S/T	0.72	0.60	0.41	-	0.74	0.62	0.43	-	0.76	0.64	0.44	-	0.79	0.66	0.46	-	0.82	0.68	0.47	-	0.82	0.69	0.48	-	
		ΔT	17	15	11	-	17	15	11	-	17	15	11	-	18	15	12	-	17	15	11	-	16	14	11	-	
	1150	kW	2.40	2.45	2.52	-	2.57	2.62	2.70	-	2.72	2.77	2.85	-	2.85	2.91	2.99	-	2.96	3.02	3.11	-	3.05	3.12	3.22	-	
		Amps	8.4	8.6	8.9	-	9.1	9.3	9.6	-	9.9	10.1	10.4	-	10.5	10.8	11.1	-	11.2	11.4	11.8	-	11.8	12.1	12.5	-	
		Hi PR	241	260	263	-	273	293	298	-	310	334	338	-	354	380	386	-	382	411	416	-	453	487	493	-	
	1000	Lo PR	120	124	135	-	123	127	139	-	127	131	144	-	131	135	147	-	133	138	150	-	137	141	154	-	
		MBh	32.9	34.1	37.4	-	32.2	33.3	36.5	-	31.4	32.5	35.6	-	30.6	31.7	34.8	-	29.1	30.2	33.0	-	26.9	27.9	30.6	-	
		S/T	0.68	0.57	0.40	-	0.71	0.59	0.41	-	0.73	0.61	0.42	-	0.75	0.63	0.43	-	0.78	0.65	0.45	-	0.79	0.66	0.45	-	
	75	1300	ΔT	18	16	12	-	18	16	12	-	18	16	12	-	18	16	12	-	18	16	12	-	17	15	11	-
			kW	2.38	2.43	2.50	-	2.55	2.60	2.68	-	2.70	2.75	2.83	-	2.83	2.88	2.97	-	2.94	3.00	3.09	-	3.03	3.09	3.19	-
			Amps	8.4	8.6	8.8	-	9.0	9.2	9.5	-	9.8	10.0	10.3	-	10.4	10.7	11.0	-	11.1	11.3	11.7	-	11.7	12.0	12.4	-
1150		Hi PR	239	257	261	-	270	291	295	-	307	330	335	-	350	376	382	-	378	406	412	-	448	482	489	-	
		Lo PR	119	122	133	-	122	126	137	-	126	130	142	-	130	134	146	-	132	136	149	-	135	140	152	-	
		MBh	30.4	31.5	34.5	-	29.7	30.8	33.7	-	29.0	30.0	32.9	-	28.3	29.3	32.1	-	26.9	27.8	30.5	-	24.9	25.8	28.2	-	
1000		S/T	0.66	0.55	0.38	-	0.68	0.57	0.40	-	0.70	0.59	0.41	-	0.72	0.60	0.42	-	0.75	0.63	0.43	-	0.76	0.63	0.44	-	
		ΔT	18	16	12	-	19	16	12	-	19	16	12	-	19	16	12	-	19	16	12	-	17	15	11	-	
		kW	2.37	2.41	2.48	-	2.53	2.58	2.66	-	2.68	2.73	2.81	-	2.80	2.86	2.95	-	2.91	2.97	3.06	-	3.01	3.07	3.16	-	
70		1300	Amps	8.3	8.5	8.7	-	8.9	9.1	9.4	-	9.7	9.9	10.2	-	10.3	10.6	10.9	-	11.0	11.2	11.6	-	11.6	11.9	12.3	-
			Hi PR	237	254	258	-	268	288	292	-	304	327	332	-	347	373	378	-	374	402	408	-	444	477	484	-
			Lo PR	117	121	132	-	121	125	136	-	125	129	141	-	128	132	144	-	131	135	147	-	134	138	151	-
	1150	MBh	34.5	35.5	38.4	41.2	33.7	34.7	37.5	40.3	32.9	33.8	36.6	39.3	32.1	33.0	35.7	38.4	30.5	31.4	34.0	36.4	28.2	29.1	31.5	33.8	
		S/T	0.81	0.73	0.55	0.35	0.84	0.76	0.57	0.37	0.87	0.77	0.59	0.38	0.89	0.80	0.61	0.39	0.93	0.83	0.63	0.40	0.94	0.84	0.63	0.41	
		ΔT	20	18	15	10	20	19	15	10	20	19	15	10	20	19	15	11	20	18	15	10	19	17	14	10	
	1000	kW	2.40	2.45	2.52	2.59	2.57	2.62	2.70	2.78	2.72	2.77	2.85	2.94	2.85	2.91	2.99	3.09	2.96	3.02	3.11	3.21	3.05	3.12	3.22	3.32	
		Amps	8.4	8.6	8.9	9.2	9.1	9.3	9.6	9.9	9.9	10.1	10.4	10.8	10.5	10.8	11.1	11.5	11.2	11.4	11.8	12.2	11.8	12.1	12.5	13.0	
		Hi PR	241	260	263	269	273	293	298	304	310	334	338	346	354	380	386	394	382	411	416	426	453	487	493	504	
	75	Lo PR	120	124	135	144	123	127	139	148	127	131	144	153	131	135	147	157	133	138	150	160	137	141	154	164	
		MBh	33.5	34.5	37.3	40.0	32.7	33.7	36.4	39.1	31.9	32.9	35.6	38.2	31.1	32.1	34.7	37.2	29.6	30.5	33.0	35.4	27.4	28.2	30.5	32.8	
		S/T	0.78	0.70	0.53	0.34	0.81	0.72	0.55	0.35	0.83	0.74	0.56	0.36	0.85	0.76	0.58	0.37	0.88	0.79	0.60	0.39	0.89	0.80	0.60	0.39	
1150	ΔT	21	19	16	11	21	19	16	11	21	19	16	11	21	20	16	11	21	19	16	11	20	18	15	10		
	kW	2.38	2.43	2.50	2.57	2.55	2.60	2.68	2.76	2.70	2.75	2.83	2.92	2.83	2.88	2.97	3.06	2.94	3.00	3.09	3.19	3.03	3.09	3.19	3.29		
	Amps	8.4	8.6	8.8	9.1	9.0	9.2	9.5	9.9	9.8	10.0	10.3	10.7	10.4	10.7	11.0	11.4	11.1	11.3	11.7	12.1	11.7	12.0	12.4	12.8		
1000	Hi PR	239	257	261	266	270	291	295	301	307	330	335	343	350	376	382	390	378	406	412	421	448	482	489	499		
	Lo PR	119	122	133	142	122	126	137	146	126	130	142	151	130	134	146	155	132	136	149	158	135	140	152	162		
	MBh	30.9	31.8	34.4	37.0	30.2	31.1	33.6	36.1	29.5	30.3	32.8	35.2	28.7	29.6	32.0	34.4	27.3	28.1	30.4	32.7	25.3	26.0	28.2	30.3		
75	S/T	0.75	0.67	0.51	0.33	0.78	0.69	0.53	0.34	0.80	0.71	0.54	0.35	0.82	0.74	0.56	0.36	0.85	0.76	0.58	0.37	0.86	0.77	0.58	0.37		
	ΔT	21	20	16	11	22	20	16	11	22	20	16	11	22	20	16	11	22	20	16	11	20	18	15	10		
	kW	2.37	2.41	2.48	2.55	2.53	2.58	2.66	2.74	2.68	2.73	2.81	2.90	2.80	2.86	2.95	3.04	2.91	2.97	3.06	3.16	3.01	3.07	3.16	3.27		
1000	Amps	8.3	8.5	8.7	9.1	8.9	9.1	9.4	9.8	9.7	9.9	10.2	10.6	10.3	10.6	10.9	11.3	11.0	11.2	11.6	12.0	11.6	11.9	12.3	12.7		
	Hi PR	237	254	258	264	268	288	292	298	304	327	332	339	347	373	378	386	374	402	408	417	444	477	484	494		
	Lo PR	117	121	132	141	121	125	136	145	125	129	141	150	128	132	144	154	131	135	147	157	134	138	151	161		

IDB: Entering Indoor Dry Bulb Temperature
 High and low pressures are measured at the liquid and suction service valves.
 kW = Total system power
 Design Subcooling @ ARI 95°F Conditions, 5° ±2°F @ the Service Valve
 Amps = outdoor unit amps (comp + fan)

EXPANDED COOLING DATA — WAC4436AA* / CA*F3642C6A* / WC*3642P4* / .067 ORIFICE (CONT.)

IDB*		Outdoor Ambient Temperature																								
		65°F				75°F				85°F				95°F				105°F				115°F				
		Airflow	59	63	67	71	59	63	67	71	59	63	67	71	59	63	67	71	59	63	67	71	59	63	67	71
IDB*		Airflow	59	63	67	71	59	63	67	71	59	63	67	71	59	63	67	71	59	63	67	71	59	63	67	71
IDB*		Airflow	59	63	67	71	59	63	67	71	59	63	67	71	59	63	67	71	59	63	67	71	59	63	67	71
		MBh	35.1	35.9	38.3	41.0	34.3	35.0	37.4	40.0	33.5	34.2	36.5	39.0	32.6	33.4	35.6	38.1	31.0	31.7	33.9	36.2	28.7	29.4	31.4	33.5
		S/T	0.89	0.84	0.68	0.51	0.93	0.87	0.71	0.53	0.95	0.89	0.73	0.54	1.00	0.92	0.75	0.56	1.00	0.95	0.78	0.58	1.00	0.96	0.78	0.59
		ΔT	2.2	2.0	1.8	1.5	2.2	2.0	1.9	1.5	2.2	2.0	1.9	1.5	2.3	2.2	1.9	1.5	2.2	2.1	1.9	1.5	2.0	2.0	1.7	1.4
1300		kW	2.40	2.45	2.52	2.59	2.57	2.62	2.70	2.78	2.72	2.77	2.85	2.94	2.85	2.91	2.99	3.09	2.96	3.02	3.11	3.21	3.05	3.12	3.22	3.32
		Amps	8.4	8.6	8.9	9.2	9.1	9.3	9.6	9.9	9.9	10.1	10.4	10.8	10.5	10.8	11.1	11.5	11.2	11.4	11.8	12.2	11.8	12.1	12.5	13.0
		HiPR	241	260	263	269	273	293	298	304	310	334	338	346	354	380	386	394	382	411	416	426	453	487	493	504
		LoPR	120	124	135	144	123	127	139	148	127	131	144	153	131	135	147	157	133	138	150	160	137	141	154	164
		MBh	34.1	34.8	37.2	39.8	33.3	34.0	36.3	38.8	32.5	33.2	35.5	37.9	31.7	32.4	34.6	37.0	30.1	30.8	32.9	35.1	27.9	28.5	30.4	32.5
80		S/T	0.85	0.80	0.65	0.49	0.88	0.83	0.67	0.50	0.91	0.85	0.69	0.52	0.94	0.88	0.71	0.53	0.97	0.91	0.74	0.55	0.98	0.92	0.75	0.56
		ΔT	2.3	2.2	1.9	1.5	2.4	2.3	2.0	1.6	2.4	2.3	2.0	1.6	2.4	2.3	2.0	1.6	2.3	2.2	1.9	1.6	2.2	2.1	1.8	1.5
		kW	2.38	2.43	2.50	2.57	2.55	2.60	2.68	2.76	2.70	2.75	2.83	2.92	2.83	2.88	2.97	3.06	2.94	3.00	3.09	3.19	3.03	3.09	3.19	3.29
		Amps	8.4	8.6	8.8	9.1	9.0	9.2	9.5	9.9	9.8	10.0	10.3	10.7	10.4	10.7	11.0	11.4	11.1	11.3	11.7	12.1	11.7	12.0	12.4	12.8
		HiPR	239	257	261	266	270	291	295	301	307	330	335	343	350	376	382	390	378	406	412	421	448	482	489	499
		LoPR	119	122	133	142	122	126	137	146	126	130	142	151	130	134	146	155	132	136	149	158	135	140	152	162
		MBh	31.4	32.1	34.3	36.7	30.7	31.4	33.5	35.8	30.0	30.6	32.7	35.0	29.3	29.9	31.9	34.1	27.8	28.4	30.3	32.4	25.7	26.3	28.1	30.0
1000		S/T	0.82	0.77	0.63	0.47	0.85	0.80	0.65	0.49	0.87	0.82	0.67	0.50	0.90	0.85	0.69	0.51	0.94	0.88	0.71	0.53	0.94	0.89	0.72	0.54
		ΔT	2.4	2.3	2.0	1.6	2.4	2.3	2.0	1.6	2.4	2.3	2.0	1.6	2.4	2.3	2.0	1.6	2.4	2.3	2.0	1.6	2.2	2.1	1.9	1.5
		kW	2.37	2.41	2.48	2.55	2.53	2.58	2.66	2.74	2.68	2.73	2.81	2.90	2.80	2.86	2.95	3.04	2.91	2.97	3.06	3.16	3.01	3.07	3.16	3.27
		Amps	8.3	8.5	8.7	9.1	8.9	9.1	9.4	9.8	9.7	9.9	10.2	10.6	10.3	10.6	10.9	11.3	11.0	11.2	11.6	12.0	11.6	11.9	12.3	12.7
		HiPR	237	254	258	264	268	288	292	298	304	327	332	339	347	373	378	386	374	402	408	417	444	477	484	494
		LoPR	117	121	132	141	121	125	136	145	125	129	141	150	128	132	144	154	131	135	147	157	134	138	151	161
		MBh	35.7	36.4	38.1	40.7	34.9	35.6	37.2	39.7	34.0	34.7	36.3	38.8	33.2	33.9	35.5	37.8	31.6	32.2	33.7	35.9	29.2	29.8	31.2	33.3
1300		S/T	0.94	0.90	0.82	0.66	0.97	0.94	0.85	0.69	1.00	0.96	0.87	0.70	1.00	0.99	0.90	0.73	1.00	1.00	0.93	0.75	1.00	1.00	0.94	0.76
		ΔT	2.4	2.3	2.2	1.9	2.4	2.4	2.2	1.9	2.4	2.4	2.2	1.9	2.3	2.4	2.2	1.9	2.2	2.3	2.2	1.9	2.1	2.1	2.1	1.8
		kW	2.40	2.45	2.52	2.59	2.57	2.62	2.70	2.78	2.72	2.77	2.85	2.94	2.85	2.91	2.99	3.09	2.96	3.02	3.11	3.21	3.05	3.12	3.22	3.32
		Amps	8.4	8.6	8.9	9.2	9.1	9.3	9.6	9.9	9.9	10.1	10.4	10.8	10.5	10.8	11.1	11.5	11.2	11.4	11.8	12.2	11.8	12.1	12.5	13.0
		HiPR	241	260	263	269	273	293	298	304	310	334	338	346	354	380	386	394	382	411	416	426	453	487	493	504
		LoPR	120	124	135	144	123	127	139	148	127	131	144	153	131	135	147	157	133	138	150	160	137	141	154	164
		MBh	34.7	35.3	37.0	39.5	33.9	34.5	36.1	38.6	33.1	33.7	35.3	37.6	32.2	32.9	34.4	36.7	30.6	31.2	32.7	34.9	28.4	28.9	30.3	32.3
85		S/T	0.89	0.86	0.78	0.63	0.93	0.89	0.81	0.65	0.95	0.92	0.83	0.67	0.98	0.95	0.85	0.69	1.00	0.98	0.89	0.72	1.00	0.99	0.89	0.72
		ΔT	2.5	2.4	2.3	2.0	2.5	2.5	2.3	2.0	2.5	2.5	2.3	2.0	2.5	2.5	2.3	2.0	2.4	2.5	2.3	2.0	2.3	2.3	2.2	1.9
		kW	2.38	2.43	2.50	2.57	2.55	2.60	2.68	2.76	2.70	2.75	2.83	2.92	2.83	2.88	2.97	3.06	2.94	3.00	3.09	3.19	3.03	3.09	3.19	3.29
		Amps	8.4	8.6	8.8	9.1	9.0	9.2	9.5	9.9	9.8	10.0	10.3	10.7	10.4	10.7	11.0	11.4	11.1	11.3	11.7	12.1	11.7	12.0	12.4	12.8
		HiPR	239	257	261	266	270	291	295	301	307	330	335	343	350	376	382	390	378	406	412	421	448	482	489	499
		LoPR	119	122	133	142	122	126	137	146	126	130	142	151	130	134	146	155	132	136	149	158	135	140	152	162
		MBh	32.0	32.6	34.2	36.4	31.3	31.9	33.4	35.6	30.5	31.1	32.6	34.7	29.8	30.3	31.8	33.9	28.3	28.8	30.2	32.2	26.2	26.7	28.0	29.8
1000		S/T	0.86	0.83	0.75	0.61	0.89	0.86	0.78	0.63	0.92	0.88	0.80	0.65	0.95	0.91	0.82	0.67	0.98	0.95	0.85	0.69	0.99	0.95	0.86	0.70
		ΔT	2.5	2.5	2.4	2.0	2.6	2.5	2.4	2.1	2.6	2.5	2.4	2.1	2.6	2.5	2.4	2.1	2.6	2.5	2.4	2.1	2.6	2.5	2.4	2.1
		kW	2.37	2.41	2.48	2.55	2.53	2.58	2.66	2.74	2.68	2.73	2.81	2.90	2.80	2.86	2.95	3.04	2.91	2.97	3.06	3.16	3.01	3.07	3.16	3.27
		Amps	8.3	8.5	8.7	9.1	8.9	9.1	9.4	9.8	9.7	9.9	10.2	10.6	10.3	10.6	10.9	11.3	11.0	11.2	11.6	12.0	11.6	11.9	12.3	12.7
		HiPR	237	254	258	264	268	288	292	298	304	327	332	339	347	373	378	386	374	402	408	417	444	477	484	494
		LoPR	117	121	132	141	121	125	136	145	125	129	141	150	128	132	144	154	131	135	147	157	134	138	151	161

IDB: Entering Indoor Dry Bulb Temperature Shaded area reflects ARI conditions High and low pressures are measured at the liquid and suction service valves.

kW = Total system power
Amps = outdoor unit amps (comp+fan)
Design Subcooling @ ARI 95°F Conditions. 5° ±2°F @ the Service Valve

PRODUCT SPECIFICATIONS

EXPANDED COOLING DATA — WAC4442AB* / CA*F4860C6A* / WC*4860P4* / .074 ORIFICE

IDB*	Airflow	Outdoor Ambient Temperature																							
		65°F				75°F				85°F				95°F				105°F				115°F			
		59	63	67	71	59	63	67	71	59	63	67	71	59	63	67	71	59	63	67	71	59	63	67	71
70	MBh	39.2	40.6	44.5	-	38.3	39.7	43.5	-	37.4	38.7	42.4	-	36.5	37.8	41.4	-	34.6	35.9	39.3	-	32.1	33.3	36.4	-
	S/T	0.71	0.60	0.41	-	0.74	0.62	0.43	-	0.76	0.63	0.44	-	0.78	0.65	0.45	-	0.81	0.68	0.47	-	0.82	0.68	0.47	-
	ΔT	18	16	12	-	19	16	12	-	19	16	12	-	19	16	12	-	18	16	12	-	17	15	11	-
	KW	2.71	2.77	2.85	-	2.91	2.96	3.05	-	3.07	3.13	3.23	-	3.22	3.29	3.39	-	3.35	3.42	3.52	-	3.46	3.53	3.64	-
	Amps	9.9	10.1	10.4	-	10.6	10.9	11.2	-	11.5	11.8	12.2	-	12.3	12.6	13.0	-	13.0	13.4	13.8	-	13.8	14.1	14.6	-
	Hi PR	228	245	249	-	258	277	281	-	293	315	320	-	334	359	364	-	375	404	409	-	420	452	459	-
	Lo PR	118	121	133	-	121	125	137	-	125	129	141	-	129	133	145	-	131	135	148	-	134	139	151	-
	MBh	38.1	39.4	43.2	-	37.2	38.5	42.2	-	36.3	37.6	41.2	-	35.4	36.7	40.2	-	33.6	34.9	38.2	-	31.2	32.3	35.4	-
	S/T	0.68	0.57	0.39	-	0.71	0.59	0.41	-	0.72	0.60	0.42	-	0.75	0.62	0.43	-	0.78	0.65	0.45	-	0.78	0.65	0.45	-
	ΔT	19	16	13	-	19	17	13	-	19	17	13	-	19	17	13	-	19	17	13	-	18	16	12	-
	KW	2.70	2.75	2.83	-	2.88	2.94	3.03	-	3.05	3.11	3.20	-	3.20	3.26	3.36	-	3.32	3.39	3.49	-	3.43	3.50	3.61	-
	Amps	9.8	10.0	10.3	-	10.5	10.8	11.1	-	11.4	11.7	12.1	-	12.2	12.5	12.9	-	12.9	13.2	13.7	-	13.7	14.0	14.5	-
Hi PR	226	243	246	-	255	274	278	-	290	312	316	-	330	355	360	-	372	400	405	-	416	448	454	-	
Lo PR	117	120	131	-	120	124	135	-	124	128	140	-	127	131	144	-	130	134	146	-	133	137	150	-	
MBh	35.1	36.4	39.9	-	34.3	35.6	39.0	-	33.5	34.7	38.0	-	32.7	33.9	37.1	-	31.0	32.2	35.2	-	28.8	29.8	32.7	-	
S/T	0.66	0.55	0.38	-	0.68	0.57	0.39	-	0.70	0.58	0.40	-	0.72	0.60	0.42	-	0.75	0.62	0.43	-	0.75	0.63	0.44	-	
ΔT	19	17	13	-	20	17	13	-	20	17	13	-	20	17	13	-	19	17	13	-	18	16	12	-	
KW	2.68	2.73	2.81	-	2.86	2.92	3.00	-	3.03	3.09	3.18	-	3.17	3.24	3.33	-	3.30	3.36	3.47	-	3.40	3.47	3.58	-	
Amps	9.7	9.9	10.2	-	10.4	10.7	11.0	-	11.3	11.6	11.9	-	12.1	12.3	12.7	-	12.8	13.1	13.5	-	13.6	13.9	14.3	-	
Hi PR	223	240	244	-	253	272	275	-	287	309	313	-	327	352	357	-	368	396	401	-	412	443	449	-	
Lo PR	115	119	130	-	119	123	134	-	123	127	138	-	126	130	142	-	129	133	145	-	132	136	148	-	
75	MBh	39.9	41.0	44.4	47.7	38.9	40.1	43.4	46.6	38.0	39.1	42.4	45.5	37.1	38.2	41.3	44.4	35.2	36.3	39.3	42.1	32.6	33.6	36.4	39.0
	S/T	0.81	0.73	0.55	0.35	0.84	0.75	0.57	0.37	0.86	0.77	0.58	0.38	0.89	0.80	0.60	0.39	0.92	0.83	0.63	0.40	0.93	0.83	0.63	0.41
	ΔT	21	19	16	11	21	20	16	11	21	20	16	11	22	20	16	11	21	20	16	11	20	18	15	10
	KW	2.71	2.77	2.85	2.93	2.91	2.96	3.05	3.14	3.07	3.13	3.23	3.33	3.22	3.29	3.39	3.49	3.35	3.42	3.52	3.63	3.46	3.53	3.64	3.75
	Amps	9.9	10.1	10.4	10.8	10.6	10.9	11.2	11.6	11.5	11.8	12.2	12.6	12.3	12.6	13.0	13.5	13.0	13.4	13.8	14.3	13.8	14.1	14.6	15.1
	Hi PR	228	245	249	254	258	277	281	287	293	315	320	327	334	359	364	372	375	404	409	418	420	452	459	469
	Lo PR	118	121	133	141	121	125	137	145	125	129	141	150	129	133	145	154	131	135	148	157	134	139	151	161
	MBh	38.7	39.8	43.1	46.3	37.8	38.9	42.1	45.2	36.9	38.0	41.1	44.1	36.0	37.1	40.1	43.1	34.2	35.2	38.1	40.9	31.7	32.6	35.3	37.9
	S/T	0.77	0.69	0.52	0.34	0.80	0.72	0.54	0.35	0.82	0.74	0.56	0.36	0.85	0.76	0.57	0.37	0.88	0.79	0.60	0.38	0.89	0.79	0.60	0.39
	ΔT	22	20	17	11	22	21	17	12	22	21	17	12	22	21	17	12	22	20	17	12	21	19	16	11
	KW	2.70	2.75	2.83	2.91	2.88	2.94	3.03	3.12	3.05	3.11	3.20	3.30	3.20	3.26	3.36	3.47	3.32	3.39	3.49	3.60	3.43	3.50	3.61	3.72
	Amps	9.8	10.0	10.3	10.7	10.5	10.8	11.1	11.5	11.4	11.7	12.1	12.5	12.2	12.5	12.9	13.3	12.9	13.2	13.7	14.2	13.7	14.0	14.5	15.0
Hi PR	226	243	246	251	255	274	278	284	290	312	316	323	330	355	360	368	372	400	405	414	416	448	454	464	
Lo PR	117	120	131	140	120	124	135	144	124	128	140	149	127	131	144	153	130	134	146	156	133	137	150	160	
MBh	35.7	36.8	39.8	42.7	34.9	35.9	38.9	41.7	34.1	35.1	38.0	40.7	33.2	34.2	37.0	39.7	31.6	32.5	35.2	37.8	29.2	30.1	32.6	35.0	
S/T	0.75	0.67	0.51	0.32	0.77	0.69	0.52	0.34	0.79	0.71	0.54	0.35	0.82	0.73	0.55	0.36	0.85	0.76	0.58	0.37	0.86	0.77	0.58	0.37	
ΔT	22	21	17	12	23	21	17	12	23	21	17	12	23	21	17	12	23	21	17	12	21	19	16	11	
KW	2.68	2.73	2.81	2.89	2.86	2.92	3.00	3.09	3.03	3.09	3.18	3.28	3.17	3.24	3.33	3.44	3.30	3.36	3.47	3.58	3.40	3.47	3.58	3.69	
Amps	9.7	9.9	10.2	10.6	10.4	10.7	11.0	11.4	11.3	11.6	11.9	12.4	12.1	12.3	12.7	13.2	12.8	13.1	13.5	14.0	13.6	13.9	14.3	14.9	
Hi PR	223	240	244	249	253	272	275	281	287	309	313	320	327	352	357	365	368	396	401	410	412	443	449	459	
Lo PR	115	119	130	138	119	123	134	143	123	127	138	147	126	130	142	151	129	133	145	154	132	136	148	158	

IDB: Entering Indoor Dry Bulb Temperature
 High and low pressures are measured at the liquid and suction service valves.
 Shaded area reflects ACCA (TVA) conditions
 kW = Total system power
 Design Subcooling @ ARI 95°F Conditions, 5° ±2°F @ the Service Valve
 Amps = outdoor unit amps (comp.+fan)

EXPANDED COOLING DATA — WAC4442AB* / CA*F4860C6A* / WC*4860P4* / .074 ORIFICE (CONT.)

IDB*	Airflow	Outdoor Ambient Temperature												Entering Indoor Wet Bulb Temperature											
		65°F				75°F				85°F				95°F				105°F				115°F			
		59	63	67	71	59	63	67	71	59	63	67	71	59	63	67	71	59	63	67	71	59	63	67	71
80	MBh	40.6	41.5	44.3	47.3	39.6	40.5	43.3	46.2	38.7	39.5	42.2	45.1	37.7	38.6	41.2	44.0	35.9	36.6	39.1	41.8	33.2	33.9	36.3	38.8
	S/T	0.89	0.83	0.68	0.51	0.92	0.86	0.70	0.53	0.95	0.89	0.72	0.54	1.00	0.92	0.75	0.56	1.00	0.95	0.77	0.58	1.00	0.96	0.78	0.58
	ΔT	24	23	20	16	24	23	20	16	24	23	20	16	25	23	20	16	23	23	20	16	22	21	18	15
	KW	2.71	2.77	2.85	2.93	2.91	2.96	3.05	3.14	3.07	3.13	3.23	3.33	3.22	3.29	3.39	3.49	3.35	3.42	3.52	3.63	3.46	3.53	3.64	3.75
	Amps	9.9	10.1	10.4	10.8	10.6	10.9	11.2	11.6	11.5	11.8	12.2	12.6	12.3	12.6	13.0	13.5	13.0	13.4	13.8	14.3	13.8	14.1	14.6	15.1
	Hi PR	228	245	249	254	258	277	281	287	293	315	320	327	334	359	364	372	375	404	409	418	420	452	459	469
	Lo PR	118	121	133	141	121	125	137	145	125	129	141	150	129	133	145	154	131	135	148	157	134	139	151	161
	MBh	39.4	40.2	43.0	46.0	38.5	39.3	42.0	44.9	37.6	38.4	41.0	43.8	36.6	37.4	40.0	42.8	34.8	35.6	38.0	40.6	32.2	32.9	35.2	37.6
	S/T	0.85	0.80	0.65	0.48	0.88	0.82	0.67	0.50	0.90	0.85	0.69	0.51	0.93	0.87	0.71	0.53	0.97	0.91	0.74	0.55	0.97	0.91	0.74	0.56
	ΔT	25	24	20	16	25	24	21	17	25	24	21	17	25	24	21	17	25	24	21	16	23	22	19	15
	KW	2.70	2.75	2.83	2.91	2.88	2.94	3.03	3.12	3.05	3.11	3.20	3.30	3.20	3.26	3.36	3.47	3.32	3.39	3.49	3.60	3.43	3.50	3.61	3.72
	Amps	9.8	10.0	10.3	10.7	10.5	10.8	11.1	11.5	11.4	11.7	12.1	12.5	12.2	12.5	12.9	13.3	12.9	13.2	13.7	14.2	13.7	14.0	14.5	15.0
Hi PR	226	243	246	251	255	274	278	284	290	312	316	323	330	355	360	368	372	400	405	414	416	448	454	464	
Lo PR	117	120	131	140	120	124	135	144	124	128	140	149	127	131	144	153	130	134	146	156	133	137	150	160	
MBh	36.4	37.1	39.7	42.4	35.5	36.3	38.8	41.4	34.7	35.4	37.8	40.5	33.8	34.6	36.9	39.5	32.1	32.8	35.1	37.5	29.8	30.4	32.5	34.7	
S/T	0.82	0.77	0.62	0.47	0.85	0.80	0.65	0.48	0.87	0.82	0.66	0.50	0.90	0.84	0.69	0.51	0.93	0.87	0.71	0.53	0.94	0.88	0.72	0.54	
ΔT	25	24	21	17	25	24	21	17	25	24	21	17	26	24	21	17	25	24	21	17	24	23	20	16	
KW	2.68	2.73	2.81	2.89	2.86	2.92	3.00	3.09	3.03	3.09	3.18	3.28	3.17	3.24	3.33	3.44	3.30	3.36	3.47	3.58	3.40	3.47	3.58	3.69	
Amps	9.7	9.9	10.2	10.6	10.4	10.7	11.0	11.4	11.3	11.6	11.9	12.4	12.1	12.3	12.7	13.2	12.8	13.1	13.5	14.0	13.6	13.9	14.3	14.9	
Hi PR	223	240	244	249	253	272	275	281	287	309	313	320	327	352	357	365	368	396	401	410	412	443	449	459	
Lo PR	115	119	130	138	119	123	134	143	123	127	138	147	126	130	142	151	129	133	145	154	132	136	148	158	
85	MBh	41.3	42.1	44.1	47.0	40.3	41.1	43.0	45.9	39.4	40.1	42.0	44.8	38.4	39.1	41.0	43.7	36.5	37.2	38.9	41.5	33.8	34.4	36.1	38.5
	S/T	0.93	0.90	0.81	0.66	0.97	0.93	0.84	0.68	0.99	0.96	0.86	0.70	1.00	0.99	0.89	0.72	1.00	1.00	0.92	0.75	1.00	1.00	0.93	0.76
	ΔT	25	25	23	20	25	25	24	21	26	25	24	21	25	25	24	21	24	24	24	20	22	23	22	19
	KW	2.71	2.77	2.85	2.93	2.91	2.96	3.05	3.14	3.07	3.13	3.23	3.33	3.22	3.29	3.39	3.49	3.35	3.42	3.52	3.63	3.46	3.53	3.64	3.75
	Amps	9.9	10.1	10.4	10.8	10.6	10.9	11.2	11.6	11.5	11.8	12.2	12.6	12.3	12.6	13.0	13.5	13.0	13.4	13.8	14.3	13.8	14.1	14.6	15.1
	Hi PR	228	245	249	254	258	277	281	287	293	315	320	327	334	359	364	372	375	404	409	418	420	452	459	469
	Lo PR	118	121	133	141	121	125	137	145	125	129	141	150	129	133	145	154	131	135	148	157	134	139	151	161
	MBh	40.1	40.9	42.8	45.6	39.1	39.9	41.8	44.6	38.2	39.0	40.8	43.5	37.3	38.0	39.8	42.5	35.4	36.1	37.8	40.3	32.8	33.4	35.0	37.4
	S/T	0.89	0.86	0.77	0.63	0.92	0.89	0.80	0.65	0.95	0.91	0.82	0.67	0.98	0.94	0.85	0.69	1.00	0.98	0.88	0.72	1.00	0.99	0.89	0.72
	ΔT	26	26	24	21	27	26	25	21	27	26	25	21	27	26	25	22	26	26	25	21	24	24	23	20
	KW	2.70	2.75	2.83	2.91	2.88	2.94	3.03	3.12	3.05	3.11	3.20	3.30	3.20	3.26	3.36	3.47	3.32	3.39	3.49	3.60	3.43	3.50	3.61	3.72
	Amps	9.8	10.0	10.3	10.7	10.5	10.8	11.1	11.5	11.4	11.7	12.1	12.5	12.2	12.5	12.9	13.3	12.9	13.2	13.7	14.2	13.7	14.0	14.5	15.0
Hi PR	226	243	246	251	255	274	278	284	290	312	316	323	330	355	360	368	372	400	405	414	416	448	454	464	
Lo PR	117	120	131	140	120	124	135	144	124	128	140	149	127	131	144	153	130	134	146	156	133	137	150	160	
MBh	37.0	37.7	39.5	42.1	36.1	36.8	38.6	41.2	35.3	36.0	37.7	40.2	34.4	35.1	36.7	39.2	32.7	33.3	34.9	37.2	30.3	30.9	32.3	34.5	
S/T	0.86	0.83	0.75	0.61	0.89	0.86	0.77	0.63	0.91	0.88	0.79	0.64	0.94	0.91	0.82	0.66	0.98	0.94	0.85	0.69	0.98	0.95	0.86	0.70	
ΔT	27	26	25	21	27	27	25	22	27	27	25	22	27	27	25	22	27	26	25	22	25	25	23	20	
KW	2.68	2.73	2.81	2.89	2.86	2.92	3.00	3.09	3.03	3.09	3.18	3.28	3.17	3.24	3.33	3.44	3.30	3.36	3.47	3.58	3.40	3.47	3.58	3.69	
Amps	9.7	9.9	10.2	10.6	10.4	10.7	11.0	11.4	11.3	11.6	11.9	12.4	12.1	12.3	12.7	13.2	12.8	13.1	13.5	14.0	13.6	13.9	14.3	14.9	
Hi PR	223	240	244	249	253	272	275	281	287	309	313	320	327	352	357	365	368	396	401	410	412	443	449	459	
Lo PR	115	119	130	138	119	123	134	143	123	127	138	147	126	130	142	151	129	133	145	154	132	136	148	158	

IDB: Entering Indoor Dry Bulb Temperature
 High and low pressures are measured at the liquid and suction service valves.
 Shaded area reflects ARI conditions
 kW = Total system power
 Design Subcooling @ ARI 95°F Conditions, 5° ±2°F @ the Service Valve
 Amps = outdoor unit amps (comp.+fan)

PRODUCT SPECIFICATIONS

EXPANDED COOLING DATA — WAC4448AA* / CA*F4860D6A* / WC*4860P4* / .079 ORIFICE

IDB*	Airflow	Outdoor Ambient Temperature																								
		65°F				75°F				85°F				95°F				105°F				115°F				
		59	63	67	71	59	63	67	71	59	63	67	71	59	63	67	71	59	63	67	71	59	63	67	71	
70	1744	MBh	45.1	46.7	51.2	-	44.0	45.6	50.0	-	43.0	44.5	48.8	-	41.9	43.5	47.6	-	39.8	41.3	45.2	-	36.9	38.2	41.9	-
		ST	0.73	0.61	0.42	-	0.76	0.63	0.44	-	0.78	0.65	0.45	-	0.80	0.67	0.47	-	0.83	0.70	0.48	-	0.84	0.70	0.49	-
		ΔT	17	15	11	-	18	15	12	-	18	15	12	-	18	15	12	-	18	15	12	-	16	14	11	-
		kW	3.06	3.11	3.20	-	3.27	3.33	3.43	-	3.45	3.52	3.63	-	3.62	3.69	3.81	-	3.76	3.84	3.95	-	3.88	3.96	4.08	-
		Amps	11.0	11.2	11.6	-	11.9	12.1	12.5	-	12.9	13.2	13.6	-	13.7	14.0	14.5	-	14.6	14.9	15.4	-	15.4	15.8	16.3	-
		Hi PR	234	252	255	-	265	285	289	-	301	324	328	-	343	369	374	-	386	415	421	-	432	464	471	-
	Lo PR	121	125	137	-	125	129	141	-	129	133	145	-	133	137	149	-	135	139	152	-	139	143	156	-	
	1550	MBh	43.8	45.4	49.7	-	42.7	44.3	48.5	-	41.7	43.2	47.4	-	40.7	42.2	46.2	-	38.7	40.1	43.9	-	35.8	37.1	40.7	-
		ST	0.70	0.58	0.40	-	0.72	0.61	0.42	-	0.74	0.62	0.43	-	0.77	0.64	0.44	-	0.80	0.66	0.46	-	0.80	0.67	0.46	-
		ΔT	18	16	12	-	18	16	12	-	18	16	12	-	19	16	12	-	18	16	12	-	17	15	11	-
		kW	3.03	3.09	3.18	-	3.24	3.31	3.40	-	3.43	3.50	3.60	-	3.59	3.67	3.78	-	3.73	3.81	3.92	-	3.85	3.93	4.05	-
		Amps	10.9	11.1	11.5	-	11.7	12.0	12.4	-	12.7	13.0	13.5	-	13.6	13.9	14.4	-	14.5	14.8	15.3	-	15.3	15.7	16.2	-
Hi PR		232	249	253	-	262	282	286	-	298	320	325	-	339	365	370	-	382	411	416	-	428	460	466	-	
Lo PR	120	124	135	-	124	128	139	-	128	132	144	-	131	135	148	-	134	138	151	-	137	141	154	-		
1356	MBh	40.4	41.9	45.9	-	39.5	40.9	44.8	-	38.5	39.9	43.7	-	37.6	38.9	42.7	-	35.7	37.0	40.5	-	33.1	34.3	37.5	-	
	ST	0.67	0.56	0.39	-	0.70	0.58	0.40	-	0.72	0.60	0.41	-	0.74	0.62	0.43	-	0.77	0.64	0.44	-	0.77	0.65	0.45	-	
	ΔT	18	16	12	-	19	16	12	-	19	16	12	-	19	16	12	-	19	16	12	-	17	15	11	-	
	kW	3.01	3.07	3.16	-	3.22	3.28	3.38	-	3.40	3.47	3.57	-	3.57	3.64	3.75	-	3.70	3.78	3.89	-	3.82	3.90	4.02	-	
	Amps	10.8	11.0	11.4	-	11.6	11.9	12.3	-	12.6	12.9	13.3	-	13.5	13.8	14.2	-	14.3	14.7	15.2	-	15.2	15.5	16.0	-	
	Hi PR	229	247	250	-	259	279	283	-	295	317	322	-	336	361	366	-	378	406	412	-	423	455	462	-	
Lo PR	119	123	134	-	122	126	138	-	127	131	143	-	130	134	146	-	133	137	149	-	136	140	153	-		

75	1744	MBh	45.8	47.2	51.1	54.8	44.8	46.1	49.9	53.6	43.7	45.0	48.7	52.3	42.6	43.9	47.5	51.0	40.5	41.7	45.1	48.5	37.5	38.6	41.8	44.9	
		ST	0.83	0.75	0.56	0.36	0.86	0.77	0.58	0.38	0.89	0.79	0.60	0.39	0.91	0.82	0.62	0.40	0.95	0.85	0.64	0.41	0.96	0.86	0.65	0.42	
		ΔT	20	19	15	10	20	19	15	11	20	19	15	11	21	19	16	11	21	20	19	15	11	19	17	14	10
		kW	3.06	3.11	3.20	3.30	3.27	3.33	3.43	3.53	3.45	3.52	3.63	3.74	3.62	3.69	3.81	3.92	3.76	3.84	3.95	4.08	3.88	3.96	4.08	4.21	
		Amps	11.0	11.2	11.6	12.0	11.9	12.1	12.5	13.0	12.9	13.2	13.6	14.1	13.7	14.0	14.5	15.1	14.6	14.9	15.4	16.0	15.4	15.8	16.3	17.0	
		Hi PR	234	252	255	261	265	285	289	295	301	324	328	335	343	369	374	382	386	415	421	430	432	464	471	481	
	Lo PR	121	125	137	145	125	129	141	150	129	133	145	155	133	137	149	159	135	139	152	162	139	143	156	166		
	1550	MBh	44.5	45.8	49.6	53.2	43.5	44.8	48.4	52.0	42.4	43.7	47.3	50.8	41.4	42.6	46.1	49.5	39.3	40.5	43.8	47.0	36.4	37.5	40.6	43.6	
		ST	0.79	0.71	0.54	0.35	0.82	0.74	0.56	0.36	0.84	0.76	0.57	0.37	0.87	0.78	0.59	0.38	0.90	0.81	0.61	0.39	0.91	0.82	0.62	0.40	
		ΔT	21	19	16	11	21	20	16	11	21	20	16	11	21	20	16	11	21	20	16	11	20	18	15	10	
		kW	3.03	3.09	3.18	3.27	3.24	3.31	3.40	3.51	3.43	3.50	3.60	3.71	3.59	3.67	3.78	3.89	3.73	3.81	3.92	4.05	3.85	3.93	4.05	4.18	
		Amps	10.9	11.1	11.5	11.9	11.7	12.0	12.4	12.9	12.7	13.0	13.5	14.0	13.6	13.9	14.4	14.9	14.5	14.8	15.3	15.9	15.3	15.7	16.2	16.8	
Hi PR		232	249	253	258	262	282	286	292	298	320	325	332	339	365	370	378	382	411	416	426	428	460	466	477		
Lo PR	120	124	135	144	124	128	139	148	128	132	144	153	131	135	148	157	134	138	151	161	137	141	154	164			
1356	MBh	41.1	42.3	45.8	49.1	40.1	41.3	44.7	48.0	39.2	40.3	43.7	46.8	38.2	39.3	42.6	45.7	36.3	37.4	40.5	43.4	33.6	34.6	37.5	40.2		
	ST	0.77	0.69	0.52	0.33	0.79	0.71	0.54	0.35	0.81	0.73	0.55	0.35	0.84	0.75	0.57	0.37	0.87	0.78	0.59	0.38	0.88	0.79	0.60	0.38		
	ΔT	21	20	16	11	22	20	16	11	22	20	16	11	22	20	16	11	22	20	16	11	20	18	15	10		
	kW	3.01	3.07	3.16	3.25	3.22	3.28	3.38	3.48	3.40	3.47	3.57	3.68	3.57	3.64	3.75	3.86	3.70	3.78	3.89	4.01	3.82	3.90	4.02	4.15		
	Amps	10.8	11.0	11.4	11.8	11.6	11.9	12.3	12.7	12.6	12.9	13.3	13.8	13.5	13.8	14.2	14.8	14.3	14.7	15.2	15.7	15.2	15.5	16.0	16.6		
	Hi PR	229	247	250	256	259	279	283	289	295	317	322	329	336	361	366	374	378	406	412	421	423	455	462	472		
Lo PR	119	123	134	143	122	126	138	147	127	131	143	152	130	134	146	156	133	137	149	159	136	140	153	163			

IDB: Entering Indoor Dry Bulb Temperature
 High and low pressures are measured at the liquid and suction service valves.
 Shaded area reflects ACCA (TVA) conditions
 kW = Total system power
 Amps = outdoor unit amps (comp. + fan)
 Design Subcooling @ ARI 95°F Conditions, 5° ±2°F @ the Service Valve

EXPANDED COOLING DATA — WAC4448AA* / CA*F4860D6A* / WC*4860P4* / .079 ORIFICEE (CONT.)

IDB*	Airflow	Outdoor Ambient Temperature																								
		65°F				75°F				85°F				95°F				105°F				115°F				
		59	63	67	71	59	63	67	71	59	63	67	71	59	63	67	71	59	63	67	71	59	63	67	71	
80	1744	MBh	46.7	47.7	50.9	54.4	45.6	46.6	49.7	53.2	44.5	45.5	48.6	51.9	43.4	44.3	47.4	50.6	41.2	42.1	45.0	48.1	38.2	39.0	41.7	44.6
		ST	0.91	0.86	0.70	0.52	0.95	0.89	0.72	0.54	1.00	0.91	0.74	0.55	1.00	0.94	0.77	0.57	1.00	1.00	0.79	0.59	1.00	1.00	0.80	0.60
		ΔT	22	22	19	15	23	22	19	15	23	22	19	15	23	22	19	15	23	22	19	15	20	21	18	14
		kW	3.06	3.11	3.20	3.30	3.27	3.33	3.43	3.53	3.45	3.52	3.63	3.74	3.62	3.69	3.81	3.92	3.76	3.84	3.95	4.08	3.88	3.96	4.08	4.21
		Amps	11.0	11.2	11.6	12.0	11.9	12.1	12.5	13.0	12.9	13.2	13.6	14.1	13.7	14.0	14.5	15.1	14.6	14.9	15.4	16.0	15.4	15.8	16.3	17.0
		Hi PR	234	252	255	261	265	285	289	295	301	324	328	335	343	369	374	382	386	415	421	430	432	464	471	481
	Lo PR	121	125	137	145	125	129	141	150	129	133	145	155	133	137	149	159	135	139	152	162	139	143	156	166	
	MBh	45.3	46.3	49.5	52.9	44.2	45.2	48.3	51.6	43.2	44.1	47.2	50.4	42.1	43.1	46.0	49.2	40.0	40.9	43.7	46.7	37.1	37.9	40.5	43.3	
	ST	0.87	0.82	0.67	0.50	0.90	0.85	0.69	0.52	0.93	0.87	0.71	0.53	0.96	0.90	0.73	0.55	0.99	0.93	0.76	0.57	1.00	0.94	0.76	0.57	
	ΔT	23	22	20	16	24	23	20	16	24	23	20	16	24	23	20	16	24	23	20	16	22	21	18	15	
	kW	3.03	3.09	3.18	3.27	3.24	3.31	3.40	3.51	3.43	3.50	3.60	3.71	3.59	3.67	3.78	3.89	3.73	3.81	3.92	4.05	3.85	3.93	4.05	4.18	
	Amps	10.9	11.1	11.5	11.9	11.7	12.0	12.4	12.9	12.7	13.0	13.5	14.0	13.6	13.9	14.4	14.9	14.5	14.8	15.3	15.9	15.3	15.7	16.2	16.8	
Hi PR	232	249	253	258	262	282	286	292	298	320	325	332	339	365	370	378	382	411	416	426	428	460	466	477		
Lo PR	120	124	135	144	124	128	139	148	128	132	144	153	131	135	148	157	134	138	151	161	137	141	154	164		
MBh	41.8	42.7	45.6	48.8	40.8	41.7	44.6	47.7	39.9	40.7	43.5	46.5	38.9	39.7	42.5	45.4	36.9	37.8	40.3	43.1	34.2	35.0	37.4	39.9		
ST	0.84	0.79	0.64	0.48	0.87	0.82	0.67	0.50	0.89	0.84	0.68	0.51	0.92	0.86	0.70	0.53	0.96	0.90	0.73	0.55	0.97	0.91	0.74	0.55		
ΔT	24	23	20	16	24	23	20	16	24	23	20	16	24	23	20	16	24	23	20	16	22	21	19	15		
kW	3.01	3.07	3.16	3.25	3.22	3.28	3.38	3.48	3.40	3.47	3.57	3.68	3.57	3.64	3.75	3.86	3.70	3.78	3.89	4.01	3.82	3.90	4.02	4.15		
Amps	10.8	11.0	11.4	11.8	11.6	11.9	12.3	12.7	12.6	12.9	13.3	13.8	13.5	13.8	14.2	14.8	14.3	14.7	15.2	15.7	15.2	15.5	16.0	16.6		
Hi PR	229	247	250	256	259	279	283	289	295	317	322	329	336	361	366	374	378	406	412	421	423	455	462	472		
Lo PR	119	123	134	143	122	126	138	147	127	131	143	152	130	134	146	156	133	137	149	159	136	140	153	163		

85	1744	MBh	47.5	48.4	50.7	54.1	46.4	47.3	49.5	52.8	45.3	46.1	48.3	51.6	44.2	45.0	47.1	50.3	42.0	42.8	44.8	47.8	38.9	39.6	41.5	44.3
		ST	0.96	0.92	0.83	0.68	0.99	0.96	0.86	0.70	1.00	0.98	0.89	0.72	1.00	1.00	0.92	0.74	1.00	1.00	0.95	0.77	1.00	1.00	0.96	0.78
		ΔT	24	24	22	19	24	24	23	20	24	24	23	20	24	23	24	23	20	22	23	22	19	20	21	18
		kW	3.06	3.11	3.20	3.30	3.27	3.33	3.43	3.53	3.45	3.52	3.63	3.74	3.62	3.69	3.81	3.92	3.76	3.84	3.95	4.08	3.88	3.96	4.08	4.21
		Amps	11.0	11.2	11.6	12.0	11.9	12.1	12.5	13.0	12.9	13.2	13.6	14.1	13.7	14.0	14.5	15.1	14.6	14.9	15.4	16.0	15.4	15.8	16.3	17.0
		Hi PR	234	252	255	261	265	285	289	295	301	324	328	335	343	369	374	382	386	415	421	430	432	464	471	481
	Lo PR	121	125	137	145	125	129	141	150	129	133	145	155	133	137	149	159	135	139	152	162	139	143	156	166	
	MBh	46.1	47.0	49.2	52.5	45.0	45.9	48.1	51.3	43.9	44.8	46.9	50.1	42.9	43.7	45.8	48.8	40.7	41.5	43.5	46.4	37.7	38.5	40.3	43.0	
	ST	0.91	0.88	0.80	0.65	0.95	0.91	0.82	0.67	0.97	0.94	0.85	0.69	1.00	0.97	0.87	0.71	1.00	1.00	0.91	0.74	1.00	1.00	0.91	0.74	
	ΔT	25	25	23	20	25	25	24	20	25	25	24	20	25	25	24	21	24	25	23	20	22	23	22	19	
	kW	3.03	3.09	3.18	3.27	3.24	3.31	3.40	3.51	3.43	3.50	3.60	3.71	3.59	3.67	3.78	3.89	3.73	3.81	3.92	4.05	3.85	3.93	4.05	4.18	
	Amps	10.9	11.1	11.5	11.9	11.7	12.0	12.4	12.9	12.7	13.0	13.5	14.0	13.6	13.9	14.4	14.9	14.5	14.8	15.3	15.9	15.3	15.7	16.2	16.8	
Hi PR	232	249	253	258	262	282	286	292	298	320	325	332	339	365	370	378	382	411	416	426	428	460	466	477		
Lo PR	120	124	135	144	124	128	139	148	128	132	144	153	131	135	148	157	134	138	151	161	137	141	154	164		
MBh	42.5	43.4	45.4	48.5	41.5	42.4	44.4	47.3	40.6	41.3	43.3	46.2	39.6	40.3	42.2	45.1	37.6	38.3	40.1	42.8	34.8	35.5	37.2	39.7		
ST	0.88	0.85	0.77	0.62	0.91	0.88	0.80	0.65	0.94	0.90	0.82	0.66	0.97	0.93	0.84	0.68	1.00	0.97	0.87	0.71	1.00	0.98	0.88	0.71		
ΔT	25	25	24	20	26	25	24	21	26	25	24	21	26	26	24	21	26	25	24	21	24	23	22	19		
kW	3.01	3.07	3.16	3.25	3.22	3.28	3.38	3.48	3.40	3.47	3.57	3.68	3.57	3.64	3.75	3.86	3.70	3.78	3.89	4.01	3.82	3.90	4.02	4.15		
Amps	10.8	11.0	11.4	11.8	11.6	11.9	12.3	12.7	12.6	12.9	13.3	13.8	13.5	13.8	14.2	14.8	14.3	14.7	15.2	15.7	15.2	15.5	16.0	16.6		
Hi PR	229	247	250	256	259	279	283	289	295	317	322	329	336	361	366	374	378	406	412	421	423	455	462	472		
Lo PR	119	123	134	143	122	126	138	147	127	131	143	152	130	134	146	156	133	137	149	159	136	140	153	163		

IDB: Entering Indoor Dry Bulb Temperature
 Shaded area reflects ARI conditions
 High and low pressures are measured at the liquid and suction service valves.

kW = Total system power
 Design Subcooling @ ARI 95°F Conditions, 5° ±2°F @ the Service Valve

Amps = outdoor unit amps (comp.+fan)

PRODUCT SPECIFICATIONS

EXPANDED COOLING DATA — WAC4460AA* / CA*F4860D6A* / WC*4860P4* / .088 ORIFICE

IDB*	Airflow	Outdoor Ambient Temperature																							
		65°F				75°F				85°F				95°F				105°F				115°F			
		59	63	67	71	59	63	67	71	59	63	67	71	59	63	67	71	59	63	67	71	59	63	67	71
2025	MBh	54.9	56.9	62.3	-	53.6	55.6	60.9	-	52.3	54.2	59.4	-	51.0	52.9	58.0	-	48.5	50.3	55.1	-	44.9	46.6	51.0	-
	ST	0.71	0.60	0.41	-	0.74	0.62	0.43	-	0.76	0.63	0.44	-	0.78	0.65	0.45	-	0.81	0.68	0.47	-	0.82	0.68	0.47	-
	ΔT	18	15	12	-	18	16	12	-	18	16	12	-	18	16	12	-	18	15	12	-	17	14	11	-
	kW	4.04	4.13	4.25	-	4.35	4.44	4.58	-	4.61	4.71	4.86	-	4.85	4.95	5.11	-	5.05	5.16	5.33	-	5.22	5.34	5.51	-
	Amps	14.5	14.8	15.3	-	15.6	16.0	16.6	-	17.0	17.4	18.0	-	18.2	18.7	19.3	-	21.3	21.8	22.6	-	22.5	23.1	23.8	-
	Hi PR	249	268	272	-	274	294	298	-	320	344	349	-	365	392	398	-	411	441	448	-	474	510	517	-
	Lo PR	117	120	132	-	120	124	135	-	124	128	140	-	128	132	144	-	130	134	147	-	133	138	150	-
	MBh	53.3	55.2	60.5	-	52.0	53.9	59.1	-	50.8	52.7	57.7	-	49.6	51.4	56.3	-	47.1	48.8	53.5	-	43.6	45.2	49.5	-
	ST	0.68	0.57	0.39	-	0.71	0.59	0.41	-	0.72	0.60	0.42	-	0.75	0.62	0.43	-	0.78	0.65	0.45	-	0.78	0.65	0.45	-
	ΔT	19	16	12	-	19	16	12	-	19	16	12	-	19	16	12	-	19	16	12	-	17	15	11	-
70	kW	4.01	4.09	4.22	-	4.31	4.40	4.54	-	4.58	4.67	4.82	-	4.81	4.91	5.07	-	5.01	5.12	5.29	-	5.18	5.30	5.47	-
	Amps	14.3	14.7	15.2	-	15.5	15.9	16.4	-	16.9	17.3	17.9	-	18.1	18.5	19.1	-	21.1	21.6	22.4	-	22.3	22.8	23.6	-
	Hi PR	247	265	269	-	271	291	296	-	317	341	346	-	361	388	394	-	406	437	443	-	470	505	512	-
	Lo PR	116	119	130	-	119	123	134	-	123	127	139	-	126	130	142	-	129	133	145	-	132	136	149	-
	MBh	49.2	51.0	55.8	-	48.0	49.8	54.5	-	46.9	48.6	53.2	-	45.7	47.4	51.9	-	43.5	45.0	49.3	-	40.3	41.7	45.7	-
	ST	0.66	0.55	0.38	-	0.68	0.57	0.39	-	0.70	0.58	0.40	-	0.72	0.60	0.42	-	0.75	0.62	0.43	-	0.75	0.63	0.44	-
	ΔT	19	16	12	-	19	17	13	-	19	17	13	-	19	17	13	-	19	16	12	-	18	15	12	-
	kW	3.98	4.06	4.19	-	4.28	4.37	4.50	-	4.54	4.64	4.78	-	4.77	4.87	5.03	-	4.97	5.08	5.24	-	5.14	5.25	5.42	-
	Amps	14.2	14.5	15.0	-	15.4	15.7	16.3	-	16.7	17.1	17.7	-	17.9	18.3	19.0	-	20.9	21.4	22.2	-	22.1	22.6	23.4	-
	Hi PR	244	263	266	-	268	288	293	-	314	338	342	-	358	385	390	-	402	433	439	-	465	500	507	-
Lo PR	114	118	129	-	118	122	133	-	122	126	137	-	125	129	141	-	128	132	144	-	131	135	147	-	

2025	MBh	55.8	57.5	62.2	66.7	54.5	56.1	60.7	65.2	53.2	54.8	59.3	63.6	51.9	53.4	57.9	62.1	49.3	50.8	55.0	59.0	45.7	47.0	50.9	54.6
	ST	0.81	0.73	0.55	0.35	0.84	0.75	0.57	0.37	0.86	0.77	0.58	0.38	0.89	0.80	0.60	0.39	0.92	0.83	0.63	0.40	0.93	0.83	0.63	0.41
	ΔT	21	19	16	11	21	19	16	11	21	19	16	11	21	19	16	11	21	19	16	11	19	18	15	10
	kW	4.04	4.13	4.25	4.39	4.35	4.44	4.58	4.72	4.61	4.71	4.86	5.02	4.85	4.95	5.11	5.28	5.05	5.16	5.33	5.51	5.22	5.34	5.51	5.70
	Amps	14.5	14.8	15.3	15.9	15.6	16.0	16.6	17.2	17.0	17.4	18.0	18.7	18.2	18.7	19.3	20.1	21.3	21.8	22.6	23.5	22.5	23.1	23.8	24.8
	Hi PR	249	268	272	278	274	294	298	305	320	344	349	357	365	392	398	407	411	441	448	458	474	510	517	529
	Lo PR	117	120	132	140	120	124	135	144	124	128	140	149	128	132	144	153	130	134	147	156	133	138	150	160
	MBh	54.2	55.8	60.4	64.8	52.9	54.5	59.0	63.3	51.7	53.2	57.6	61.8	50.4	51.9	56.2	60.3	47.9	49.3	53.4	57.3	44.4	45.7	49.4	53.0
	ST	0.77	0.69	0.52	0.34	0.80	0.72	0.54	0.35	0.82	0.74	0.56	0.36	0.85	0.76	0.57	0.37	0.88	0.79	0.60	0.38	0.89	0.79	0.60	0.39
	ΔT	21	20	16	11	22	20	16	11	22	20	16	11	22	20	16	11	22	20	16	11	20	19	15	10
75	kW	4.01	4.09	4.22	4.35	4.31	4.40	4.54	4.69	4.58	4.67	4.82	4.98	4.81	4.91	5.07	5.24	5.01	5.12	5.29	5.46	5.18	5.30	5.47	5.65
	Amps	14.3	14.7	15.2	15.7	15.5	15.9	16.4	17.0	16.9	17.3	17.9	18.6	18.1	18.5	19.1	19.9	21.1	21.6	22.4	23.2	22.3	22.8	23.6	24.5
	Hi PR	247	265	269	275	271	291	296	302	317	341	346	354	361	388	394	403	406	437	443	453	470	505	512	523
	Lo PR	116	119	130	139	119	123	134	143	123	127	139	148	126	130	142	152	129	133	145	155	132	136	149	158
	MBh	50.0	51.5	55.7	59.8	48.8	50.3	54.4	58.4	47.7	49.1	53.1	57.0	46.5	47.9	51.8	55.6	44.2	45.5	49.3	52.9	40.9	42.1	45.6	49.0
	ST	0.75	0.67	0.51	0.32	0.77	0.69	0.52	0.34	0.79	0.71	0.54	0.35	0.82	0.73	0.55	0.36	0.85	0.76	0.58	0.37	0.86	0.77	0.58	0.37
	ΔT	22	20	16	11	22	20	17	11	22	20	17	11	22	20	17	12	22	20	17	11	20	19	15	11
	kW	3.98	4.06	4.19	4.32	4.28	4.37	4.50	4.65	4.54	4.64	4.78	4.94	4.77	4.87	5.03	5.20	4.97	5.08	5.24	5.41	5.14	5.25	5.42	5.60
	Amps	14.2	14.5	15.0	15.6	15.4	15.7	16.3	16.9	16.7	17.1	17.7	18.4	17.9	18.3	19.0	19.7	20.9	21.4	22.2	23.0	22.1	22.6	23.4	24.3
	Hi PR	244	263	266	272	268	288	293	299	314	338	342	350	358	385	390	399	402	433	439	448	465	500	507	518
Lo PR	114	118	129	137	118	122	133	141	122	126	137	146	125	129	141	150	128	132	144	153	131	135	147	157	

IDB: Entering Indoor Dry Bulb Temperature
 Shaded area reflects ACCA (TVA) conditions
 High and low pressures are measured at the liquid and suction service valves.

kW = Total system power
 Design Subcooling @ ARI 95°F Conditions, 5° ±2°F @ the Service Valve

Amps = outdoor unit amps (comp. +fan)

EXPANDED COOLING DATA — WAC4460AA* / CA*F4860D6A* / WC*4860P4* / .088 ORIFICE (CONT.)

IDB*	Airflow	Outdoor Ambient Temperature																								
		65°F				75°F				85°F				95°F				105°F				115°F				
		59	63	67	71	59	63	67	71	59	63	67	71	59	63	67	71	59	63	67	71	59	63	67	71	
80	2025	MBh	56.8	58.0	62.0	66.3	55.5	56.7	60.6	64.7	54.2	55.3	59.1	63.2	52.8	54.0	57.7	61.7	50.2	51.3	54.8	58.6	46.5	47.5	50.8	54.3
		S/T	0.89	0.83	0.68	0.51	0.92	0.86	0.70	0.53	0.95	0.89	0.72	0.54	1.00	0.92	0.75	0.56	1.00	0.95	0.77	0.58	1.00	0.96	0.78	0.58
		ΔT	23	22	19	15	23	22	19	15	23	22	19	15	24	22	20	16	23	22	19	15	21	21	18	14
		kW	4.04	4.13	4.25	4.39	4.35	4.44	4.58	4.72	4.61	4.71	4.86	5.02	4.85	4.95	5.11	5.28	5.05	5.16	5.33	5.51	5.22	5.34	5.51	5.70
		Amps	14.5	14.8	15.3	15.9	15.6	16.0	16.6	17.2	17.0	17.4	18.0	18.7	18.2	18.7	19.3	20.1	21.1	21.8	22.6	23.5	22.5	23.1	23.8	24.8
		Hi PR	249	268	272	278	274	294	298	305	320	344	349	357	365	392	398	407	411	441	448	458	474	510	517	529
	Lo PR	117	120	132	140	120	124	135	144	124	128	140	149	128	132	144	153	130	134	147	156	133	138	150	160	
	MBh	55.1	56.3	60.2	64.4	53.9	55.0	58.8	62.9	52.6	53.7	57.4	61.4	51.3	52.4	56.0	59.9	48.7	49.8	53.2	56.9	45.1	46.1	49.3	52.7	
	S/T	0.85	0.80	0.65	0.48	0.88	0.82	0.67	0.50	0.90	0.85	0.69	0.51	0.93	0.87	0.71	0.53	0.97	0.91	0.74	0.55	0.97	0.91	0.74	0.56	
	ΔT	24	23	20	16	24	23	20	16	24	23	20	16	24	23	20	16	24	23	20	16	22	22	19	15	
	kW	4.01	4.09	4.22	4.35	4.31	4.40	4.54	4.69	4.58	4.67	4.82	4.98	4.81	4.91	5.07	5.24	5.01	5.12	5.29	5.46	5.18	5.30	5.47	5.65	
	Amps	14.3	14.7	15.2	15.7	15.5	15.9	16.4	17.0	16.9	17.3	17.9	18.6	18.1	18.5	19.1	19.9	21.1	21.6	22.4	23.2	22.3	22.8	23.6	24.5	
Hi PR	247	265	269	275	271	291	296	302	317	341	346	354	361	388	394	403	406	437	443	453	470	505	512	523		
Lo PR	116	119	130	139	119	123	134	143	123	127	139	148	126	130	142	152	129	133	145	155	132	136	149	158		
MBh	50.9	52.0	55.6	59.4	49.7	50.8	54.3	58.0	48.5	49.6	53.0	56.6	47.3	48.4	51.7	55.3	45.0	46.0	49.1	52.5	41.7	42.6	45.5	48.6		
S/T	0.82	0.77	0.62	0.47	0.85	0.80	0.65	0.48	0.87	0.82	0.66	0.50	0.90	0.84	0.69	0.51	0.93	0.87	0.71	0.53	0.94	0.88	0.72	0.54		
ΔT	24	23	20	16	25	24	21	16	25	24	21	16	25	24	21	16	24	23	20	16	23	22	19	15		
kW	3.98	4.06	4.19	4.32	4.28	4.37	4.50	4.65	4.54	4.64	4.78	4.94	4.77	4.87	5.03	5.20	4.97	5.08	5.24	5.41	5.14	5.25	5.42	5.60		
Amps	14.2	14.5	15.0	15.6	15.4	15.7	16.3	16.9	16.7	17.1	17.7	18.4	17.9	18.3	19.0	19.7	20.9	21.4	22.2	23.0	22.1	22.6	23.4	24.3		
Hi PR	244	263	266	272	268	288	293	299	314	338	342	350	358	385	390	399	402	433	439	448	465	500	507	518		
Lo PR	114	118	129	137	118	122	133	141	122	126	137	146	125	129	141	150	128	132	144	153	131	135	147	157		

85	2025	MBh	57.8	58.9	61.7	65.8	56.4	57.5	60.3	64.3	55.1	56.2	58.8	62.8	53.8	54.8	57.4	61.2	51.1	52.1	54.5	58.2	47.3	48.2	50.5	53.9
		S/T	0.93	0.90	0.81	0.66	0.97	0.93	0.84	0.68	0.99	0.96	0.86	0.70	1.00	0.99	0.89	0.72	1.00	1.00	0.92	0.75	1.00	1.00	0.93	0.76
		ΔT	24	24	23	20	25	24	23	20	25	24	23	20	24	25	23	20	23	24	23	20	21	22	21	19
		kW	4.04	4.13	4.25	4.39	4.35	4.44	4.58	4.72	4.61	4.71	4.86	5.02	4.85	4.95	5.11	5.28	5.05	5.16	5.33	5.51	5.22	5.34	5.51	5.70
		Amps	14.5	14.8	15.3	15.9	15.6	16.0	16.6	17.2	17.0	17.4	18.0	18.7	18.2	18.7	19.3	20.1	21.3	21.8	22.6	23.5	22.5	23.1	23.8	24.8
		Hi PR	249	268	272	278	274	294	298	305	320	344	349	357	365	392	398	407	411	441	448	458	474	510	517	529
	Lo PR	117	120	132	140	120	124	135	144	124	128	140	149	128	132	144	153	130	134	147	156	133	138	150	160	
	MBh	56.1	57.2	59.9	63.9	54.8	55.9	58.5	62.4	53.5	54.5	57.1	60.9	52.2	53.2	55.7	59.4	49.6	50.5	52.9	56.5	45.9	46.8	49.0	52.3	
	S/T	0.89	0.86	0.77	0.63	0.92	0.89	0.80	0.65	0.95	0.91	0.82	0.67	0.98	0.94	0.85	0.69	1.00	0.98	0.88	0.72	1.00	0.99	0.89	0.72	
	ΔT	25	25	24	21	26	25	24	21	26	25	24	21	26	26	24	21	25	25	24	21	23	24	22	19	
	kW	4.01	4.09	4.22	4.35	4.31	4.40	4.54	4.69	4.58	4.67	4.82	4.98	4.81	4.91	5.07	5.24	5.01	5.12	5.29	5.46	5.18	5.30	5.47	5.65	
	Amps	14.3	14.7	15.2	15.7	15.5	15.9	16.4	17.0	16.9	17.3	17.9	18.6	18.1	18.5	19.1	19.9	21.1	21.6	22.4	23.2	22.3	22.8	23.6	24.5	
Hi PR	247	265	269	275	271	291	296	302	317	341	346	354	361	388	394	403	406	437	443	453	470	505	512	523		
Lo PR	116	119	130	139	119	123	134	143	123	127	139	148	126	130	142	152	129	133	145	155	132	136	149	158		
MBh	51.8	52.8	55.3	59.0	50.6	51.6	54.0	57.6	49.4	50.3	52.7	56.2	48.2	49.1	51.4	54.9	45.8	46.7	48.9	52.1	42.4	43.2	45.3	48.3		
S/T	0.86	0.83	0.75	0.61	0.89	0.86	0.77	0.63	0.91	0.88	0.79	0.64	0.94	0.91	0.82	0.66	0.98	0.94	0.85	0.69	0.98	0.95	0.86	0.70		
ΔT	26	26	24	21	26	26	24	21	26	26	24	21	26	26	25	21	26	26	24	21	24	24	23	20		
kW	3.98	4.06	4.19	4.32	4.28	4.37	4.50	4.65	4.54	4.64	4.78	4.94	4.77	4.87	5.03	5.20	4.97	5.08	5.24	5.41	5.14	5.25	5.42	5.60		
Amps	14.2	14.5	15.0	15.6	15.4	15.7	16.3	16.9	16.7	17.1	17.7	18.4	17.9	18.3	19.0	19.7	20.9	21.4	22.2	23.0	22.1	22.6	23.4	24.3		
Hi PR	244	263	266	272	268	288	293	299	314	338	342	350	358	385	390	399	402	433	439	448	465	500	507	518		
Lo PR	114	118	129	137	118	122	133	141	122	126	137	146	125	129	141	150	128	132	144	153	131	135	147	157		

IDB: Entering Indoor Dry Bulb Temperature
 High and low pressures are measured at the liquid and suction service valves.
 kW = Total system power
 Amps = outdoor unit amps (comp.+fan)
 Design Subcooling @ ARI 95°F Conditions, 5° ±2°F @ the Service Valve

PRODUCT SPECIFICATIONS

AHRI PERFORMANCE RATINGS

Outdoor Unit	Indoor Units		Cooling Capacity (BTU/h)					AHRI #
	Coil & Blower Units	Furnace	Total	Sensible	S/T	SEER ¹	EER ²	
WAC4418AB*	CAUF3131*6B*+EEP+TXV		18,000	12,960	.72	14.0	12.0	3567564
	CAUF3131*6B*+WMAHMV1200AB*+TXV		18,400	13,248	.72	15.0	12.5	3567565
	CAUF3131*6C*+EEP+TXV		18,000	12,960	.72	14.0	12.0	3567567
	CAUF3131*6C*+WMAHMV1200AB*+TXV		18,400	13,248	.72	15.0	12.5	3567569
	CAUF3636*6C*+EEP+TXV		18,000	12,960	.72	14.0	12.0	3567575
	CAUF3636*6C*+WMAHMV1200AB*+TXV		18,400	13,248	.72	15.0	12.5	3567577
	CAUF3743*6A*+EEP+TXV		18,400	13,248	.72	14.5	12.2	3567586
	W*C3131P4*B*+EEP+TXV		18,000	12,960	.72	14.0	12.0	3565590
	W*C3131P4*B*+WMAHMV1200AB*+TXV		18,400	13,248	.72	15.0	12.5	3565591
	W*C3131P4*C*+EEP+TXV		18,000	12,960	.72	14.0	12.0	3565592
	W*C3131P4*C*+WMAHMV1200AB*+TXV		18,400	13,248	.72	15.0	12.5	3565593
	W*C3636P4*C*+EEP+TXV		18,000	12,960	.72	14.0	12.0	3565594
	W*C3636P4*C*+WMAHMV1200AB*+TXV		18,400	13,248	.72	15.0	12.5	3565595
	W*C3743P4*A*+EEP+TXV		18,400	13,248	.72	14.5	12.2	3565596
	WAHME1830P4AB*+TXV		18,000	12,960	.72	15.0	12.5	3565589
	WAHMS1931P4AB*+TXV		18,000	12,960	.72	14.0	12.0	3565588
	WAHMV1830P4AC*+TXV		18,000	12,960	.72	15.0	12.5	3565587
	WCH2430P4BC*+EEP+TXV		18,000	12,960	.72	14.0	12.0	3565597
	WCH2430P4BC*+WMAHMV1200AB*+TXV		18,000	12,960	.72	15.0	12.5	3565598
WCH3636P4BC*+EEP+TXV		18,400	13,248	.72	14.5	12.2	3565599	
WAC4424AB*	CAUF3636*6C*	WGF*28070V4*B*	23,600	16,048	.68	15.0	12.5	3567570
	CAUF3636*6C*+EEP		24,000	16,320	.68	14.0	12.0	3567573
	CAUF3636*6C*+WMAHMV1200AB*		24,000	16,320	.68	15.0	12.5	3567576
	CAUF3642*6C*+EEP		24,000	16,320	.68	14.0	12.0	3567579
	CAUF3743*6A*+EEP		24,000	16,320	.68	14.0	12.0	3567584
	CAUF3743*6A*+EEP+TXV		24,000	16,320	.68	14.5	12.2	3567587
	W*C3636P4*C*	WGF*28070V4*B*	23,600	16,048	.68	15.0	12.5	3565603
	W*C3636P4*C*+EEP		24,000	16,320	.68	14.0	12.0	3565604
	W*C3636P4*C*+WMAHMV1200AB*		24,000	16,320	.68	15.0	12.5	3565605
	W*C3642P4*C*+EEP		24,000	16,320	.68	14.0	12.0	3565606
	W*C3743P4*A*+EEP		24,000	16,320	.68	14.0	12.0	3565607
	W*C3743P4*A*+EEP+TXV		24,000	16,320	.68	14.5	12.2	3565608
	WAHME3137P4AA*		24,000	16,320	.68	15.0	12.5	3565602
	WAHMS1931P4AB*		24,000	16,320	.68	14.0	12.0	3565601
	WAHMV3137P4AA*		24,000	16,320	.68	15.0	12.5	3565600
	WCH3636P4BC*+EEP		24,000	16,320	.68	14.0	12.0	3565609
WCH3636P4BC*+EEP+TXV		24,000	16,320	.68	14.5	12.2	3565610	
WCH3636P4BC*+WMAHMV1200AB*		24,000	16,320	.68	15.0	12.5	3565611	
WAC4430AB*	CAUF3642*6C*+EEP		28,800	21,312	.74	14.0	12.0	3567580
	CAUF3743*6A*+EEP+TXV		28,800	21,312	.74	14.5	12.2	3567588
	W*C3642P4*C*+EEP		28,800	21,312	.74	14.0	12.0	3565616
	W*C3743P4*A*+EEP+TXV		28,800	21,312	.74	14.5	12.2	3565617
	WAHME3137P4AA*		29,000	21,460	.74	15.0	12.5	3565615
	WAHMS1931P4AB*		28,800	21,312	.74	14.0	12.0	3565613
	WAHMS3636P4AB*		28,000	20,720	.74	13.5	11.8	3565614
	WAHMV3137P4AA*		28,800	21,312	.74	15.0	12.5	3565612
	WCH3636P4BC*+EEP		28,800	21,312	.74	14.0	12.0	3565618
	WCH3636P4BC*+WMAHMV1200AB*		28,800	21,312	.74	15.0	12.5	3565619
	WCH3642P4DC*+EEP		28,800	21,312	.74	14.0	12.0	3565620

¹ Seasonal Energy Efficiency Ratio; Certified per AHRI 210/240 @ 80°F/ 67°F/ 95°F

² Energy Efficiency Ratio @ 80 °F/67 °F Inside - 95 °F

AHRI PERFORMANCE RATINGS (CONT.)

Outdoor Unit	Indoor Units		Cooling Capacity (BTU/h)					AHRI #
	Coil & Blower Units	Furnace	Total	Sensible	S/T	SEER ¹	EER ²	
WAC4436AA*	CAUF3636*6C*	WGF*28070V4*B*	34,000	24,100	.71	14.5	12.0	3567571
	CAUF3636*6C*+EEP		33,000	23,400	.71	13.5	11.5	3567574
	CAUF3642*6C*+EEP		34,600	24,600	.71	14.0	12.0	3567581
	CAUF3743*6A*+EEP		34,600	24,600	.71	14.0	12.0	3567585
	CAUF3743*6A*+EEP+TXV		34,600	24,600	.71	14.5	12.2	3567589
	CAUF4860*6B*+EEP		35,000	24,900	.71	14.0	12.0	3567596
	CAUF4860*6B*+WMAH MV1600AB*		34,600	24,600	.71	14.5	12.2	3567600
	W*C3636P4*C*	WGF*28070V4*B*	34,000	24,100	.71	14.5	12.0	3565625
	W*C3636P4*C*+EEP		33,000	23,400	.71	13.5	11.5	3565626
	W*C3642P4*C*+EEP		34,600	24,600	.71	14.0	12.0	3565627
	W*C3743P4*A*+EEP		34,600	24,600	.71	14.0	12.0	3565628
	W*C3743P4*A*+EEP+TXV		34,600	24,600	.71	14.5	12.2	3565629
	W*C4860P4*B*+EEP		35,000	24,900	.71	14.0	12.0	3565630
	W*C4860P4*B*+WMAH MV1600AB*		34,600	24,600	.71	14.5	12.2	3565631
	WAHME4260P4AB*		34,600	24,600	.71	15.0	12.5	3565624
	WAHMS3636P4AB*		35,000	24,900	.71	13.5	11.8	3565622
	WAHMS3743P4AB*		34,600	24,600	.71	14.0	12.0	3565623
	WAH MV4260P4AC*		34,600	24,600	.71	15.0	12.5	3565621
	WCH3636P4BC*+EEP		34,000	24,100	.71	14.0	12.0	3565632
	WCH3642P4DC*+EEP		34,600	24,600	.71	14.0	12.0	3565633
WCH3642P4DC*+WMAH MV2000AB*		35,000	24,900	.71	15.0	12.5	3565634	
WCH3743P4DB*+EEP+TXV		34,600	24,600	.71	14.5	12.2	3565635	
WAC4442AB*	CAUF3743*6A*+EEP+TXV		40,000	28,400	.71	14.5	12.2	3567590
	CAUF4860*6B*+EEP		40,000	28,400	.71	14.0	12.0	3567597
	W*C3743P4*A*+EEP+TXV		40,000	28,400	.71	14.5	12.2	3565639
	W*C4860P4*B*+EEP		40,000	28,400	.71	14.0	12.0	3565640
	WAHME4260P4AB*		40,000	28,400	.71	15.0	12.5	3565638
	WAHMS3743P4AB*		39,500	28,000	.71	14.0	12.0	3565637
	WAH MV4260P4AC*		40,000	28,400	.71	15.0	12.5	3565636
	WCH3743P4DB*+EEP+TXV		40,000	28,400	.71	14.5	12.2	3565641
	WCH4860P4DD*+EEP		40,000	28,400	.71	14.0	12.0	3565642
WCH4860P4DD*+WMAH MV2000AB*		40,000	28,400	.71	15.0	12.5	3565643	
WAC4448AA*	CAUF4860*6B*	WGF*295090V5*D*	45,500	33,200	.73	15.0	12.5	3567592
	CAUF4860*6B*+EEP		46,000	33,600	.73	14.0	12.0	3567598
	CAUF4860*6B*+WMAH MV2000AB*		46,000	33,600	.73	15.0	13.0	3567603
	CAUF4961*6A*+EEP+TXV		46,000	33,600	.73	14.5	12.0	3567607
	W*C4860P4*B*	WGF*295090V5*D*	45,500	33,200	.73	15.0	12.5	3565650
	W*C4860P4*B*+EEP		46,000	33,600	.73	14.0	12.0	3565651
	W*C4860P4*B*+WMAH MV2000AB*		46,000	33,600	.73	15.0	13.0	3565652
	W*C4961P4*A*+EEP+TXV		46,000	33,600	.73	14.5	12.0	3565653
	WAHME4260P4AB*		47,000	34,300	.73	15.0	12.5	3565648
	WAHME4260P4AB*+TXV		46,000	33,600	.73	15.0	12.0	3565649
	WAHMS3743P4AB*		46,000	33,600	.73	14.0	12.0	3565645
	WAHMS4860P4AB*		45,000	32,900	.73	14.0	12.0	3565646
	WAHMS4961P4AA*		45,000	32,900	.73	14.0	12.0	3565647
	WAH MV4260P4AC*		46,000	33,600	.73	14.5	12.2	3565644
	WCH4860P4DD*+EEP		46,000	33,600	.73	14.0	12.0	3565654
	WCH4860P4DD*+EEP+TXV		46,000	33,600	.73	14.5	12.0	3565655
WCH4860P4DD*+WMAH MV2000AB*		46,000	33,600	.73	15.5	13.0	3565656	

PRODUCT SPECIFICATIONS

AHRI PERFORMANCE RATINGS (CONT.)

Outdoor Unit	Indoor Units		Cooling Capacity (BTU/h)					AHRI #
	Coil & Blower Units	Furnace	Total	Sensible	S/T	SEER ¹	EER ²	
WAC4460AA*	CAUF4860*6B*+EEP		56,000	39,800	.71	14.0	12.0	3567599
	CAUF4860*6B*+WMAHMS2000AA*		56,000	39,800	.71	14.0	12.0	3567606
	CAUF4860*6B*+WMAHMV2000AB*		56,000	39,800	.71	15.0	12.5	3567604
	CAUF4961*6A*+EEP+TXV		56,000	39,800	.71	14.5	12.0	3567608
	W*C4860P4*B*+EEP		56,000	39,800	.71	14.0	12.0	3565664
	W*C4860P4*B*+WMAHMS2000AA*		56,000	39,800	.71	14.0	12.0	3565666
	W*C4860P4*B*+WMAHMV2000AB*		56,000	39,800	.71	15.0	12.5	3565665
	W*C4961P4*A*+EEP+TXV		56,000	39,800	.71	14.5	12.0	3565667
	WAHME4260P4AB*		57,000	40,500	.71	14.5	12.0	3565662
	WAHME4260P4AB*+TXV		56,000	39,800	.71	15.0	12.5	3565663
	WAHMS3743P4AB*		57,000	40,500	.71	13.5	11.5	3565658
	WAHMS4860P4AB*		56,000	39,800	.71	13.5	11.5	3565659
	WAHMS4961P4AA*		56,000	39,800	.71	13.5	11.5	3565660
	WAHMS4961P4AA*+TXV		56,000	39,800	.71	13.5	11.5	3565661
	WAHMV4260P4AC*		56,000	39,800	.71	14.3	11.7	3565657
	WCH4860P4DD*+EEP		56,000	39,800	.71	14.0	12.0	3565668
	WCH4860P4DD*+EEP+TXV		56,000	39,800	.71	14.5	12.0	3565669
	WCH4860P4DD*+WMAHMS2000AA*		56,000	39,800	.71	14.0	12.0	3565670

¹ Seasonal Energy Efficiency Ratio; Certified per AHRI 210/240 @ 80°F/ 67°F/ 95°F

² Energy Efficiency Ratio @ 80 °F/67 °F Inside - 95 °F

Notes

- Always check the S&R plate for electrical data on the unit being installed.
- When matching the outdoor unit to the indoor unit, use the piston supplied with the outdoor unit or what is specified on the piston kit chart supplied with the indoor unit.
- EEP - Order Part No. B13707-38 or new Solid State Board B13707-35S. Part No. B13707-38 is not interchangeable with B13707-35S. The Whirlpool Gas Furnace contains the EEP cooling time delay.

DIMENSIONS

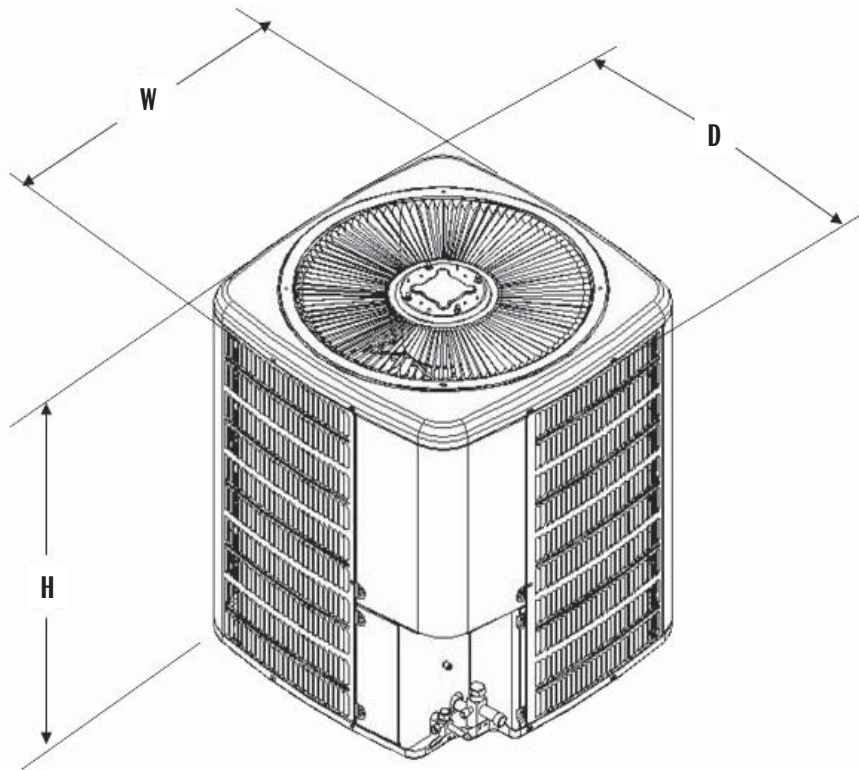

Model	Dimensions		
	W"	D"	H"
WAC4418AB*	26	26	27½
WAC4424AB*	26	26	32½
WAC4430AB*	29	29	32½
WAC4436AA*	29	29	34¼
WAC4442AB*	29	29	38¼
WAC4448AA*	35½	35½	38¼
WAC4460AA*	35½	35½	38¼

ACCESSORIES

Model	Description	WAC 4418	WAC 4424	WAC 4430	WAC 4436	WAC 4442	WAC 4448	WAC 4460
ABK-20	Anchor Bracket Kit *	X	X	X	X	X	X	X
ASC-01	Anti-Short Cycle Kit	X	X	X	X	X	X	X
CSR-U-1	Hard-start Kit	X	X	X	X			
CSR-U-2	Hard-start Kit				X	X	X	X
CSR-U-3	Hard-start Kit						X	X
FSK01A ¹	Freeze Protection Kit	X	X	X	X	X	X	X
LSK01A	Liquid Line Solenoid Kit	X	X	X	X	X	X	X
OT18-60A	Outdoor Thermostat / Lockout Stat	X	X	X	X	X	X	X
TX2N4 ²	TXV Kit	X						
TX3N4 ²	TXV Kit		X	X	X			
TX5N4 ²	TXV Kit					X	X	X

* Contains 20 brackets; four brackets needed to anchor unit to pad

¹ Installed on indoor coil

² Field-installed, non-bleed, expansion valve kit — Condensing units and heat pumps with reciprocating compressors require start-assist components when used in conjunction with an indoor coil using a non-bleed thermal expansion valve refrigerant metering device.

